

DX152

Typical Installation Instructions & Warranty Information

**Duplex Station
with Explosionproof
Grinder Pumps**

150-Gal. Capacity

Environment One Grinder Pump Feature Identification

1. **GRINDER PUMP BASIN** – Polyethylene
2. **ACCESSWAY COVER** – HDPE
3. **POWER AND ALARM CABLE** – Circuits to be installed in accordance with NEC 70 Sec 501 and local codes. Type SOOW cable, 14AWG, 75' maximum length.
4. **ALARM PANEL (not explosionproof rated)** – NEMA 4X enclosure. Equipped with circuit breakers. Locate according to local codes.
5. **ALARM DEVICE** – Every installation is to have an alarm device to alert the homeowner of a potential malfunction. Visual devices should be placed in very conspicuous locations.
6. **INLET** – EPDM grommet (4.5" ID). For 4.5" OD DWV pipe (SCH 40 std).
7. **WET WELL VENT** – 2.0" tank vent, supplied by factory in units with accessways.
8. **GRAVITY SERVICE LINE** – 4" DWV, (4.5" OD). Supplied by others (SCH 40 std).
- 8a. **STUB-OUT** – 4" X 5' Long **watertight** stub-out, to be installed at time of burial unless the gravity service line is connected during installation. Supplied by others.
9. **DISCHARGE VALVE** – 1-1/4" Female pipe thread.
10. **DISCHARGE LINE** – 1-1/4" Nominal pipe size. Supplied by others.
11. **CONCRETE ANCHOR** – See Ballast Calculations for specific weight for your station height. Supplied by others.
12. **BEDDING MATERIAL** – 6" minimum depth, round aggregate (gravel). Supplied by others.
13. **FINISHED GRADE** – Grade line to be 1 to 4 inches below removable lid and slope away from the station.
14. **REBAR** – Required to lift tank after ballast (concrete anchor) has been attached, 4 places, evenly spaced around tank.
15. **CONDUIT** – RMC or IMC threaded conduit. Supplied by others.
16. **EXPLOSIONPROOF CONDUIT SEAL** – Supplied by others.
17. **JUNCTION BOX** – Supplied by others.

Figure 1a

**FAILURE TO
COMPLY WITH
INSTALLATION
INSTRUCTIONS
WILL VOID
WARRANTY**

OUTSIDE

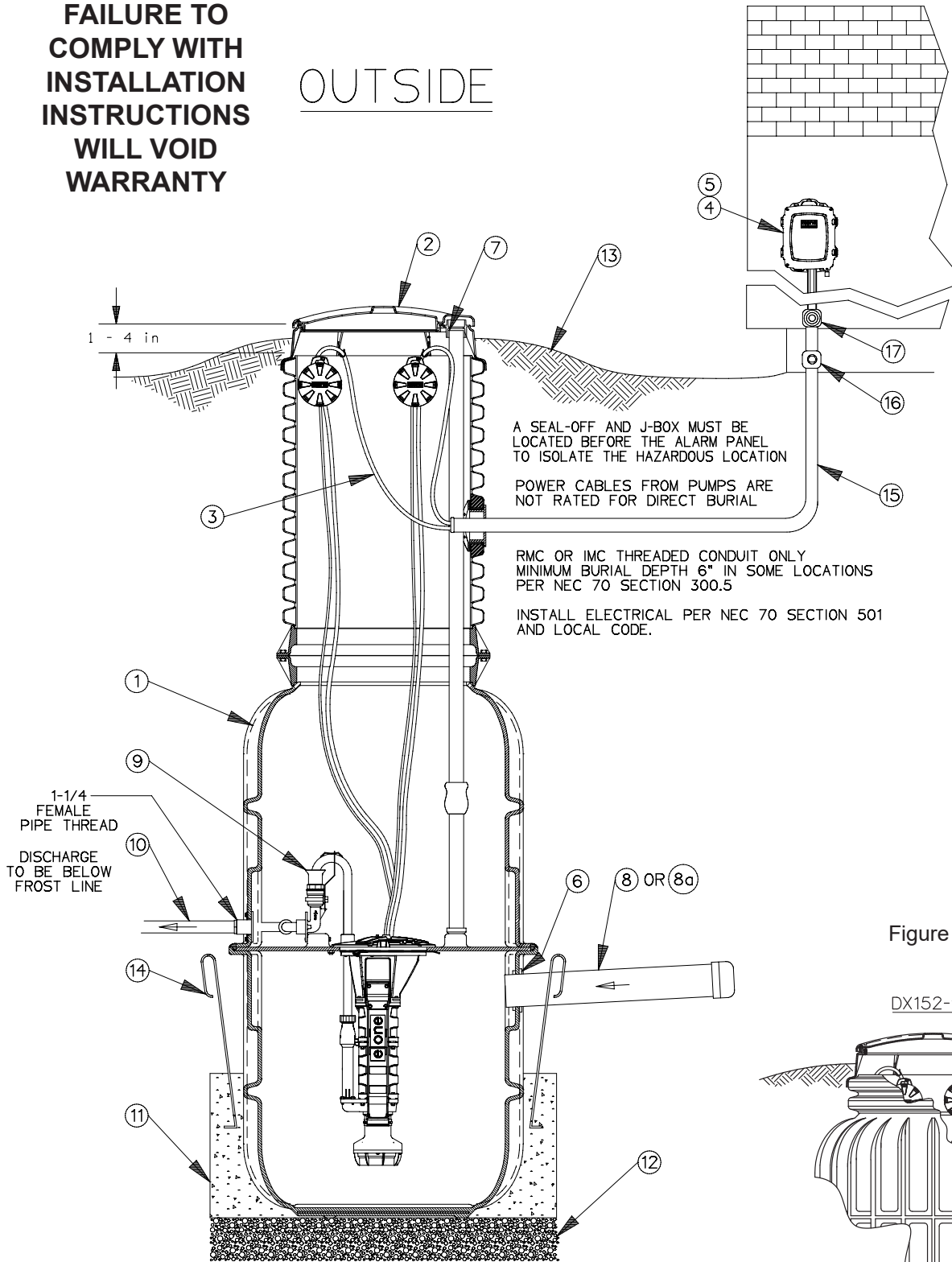
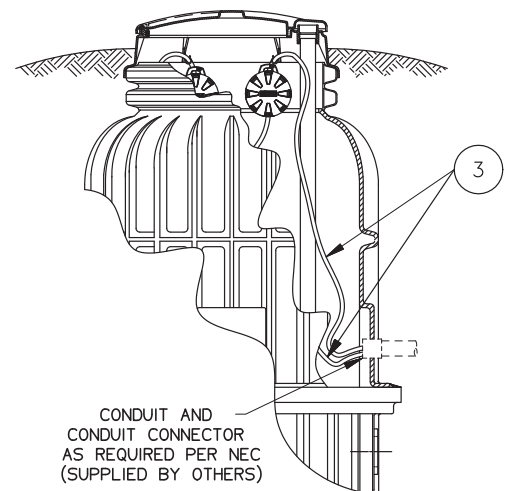

Figure 1b

DX152-93



Read all instructions before starting unit installation. If you have any questions, call your local distributor or Environment One's Service department for assistance at 518-346-6161.

No modifications can be made to this unit without affecting the Explosionproof listing, the safe operation of the product, as well as the manufacturer's warranty.

This product can only be serviced by Environment One explosionproof-certified personnel. Call Environment One's Service department at 518-346-6161.

Note: Occupational Safety and Health Standard (OSHA) mandates that anyone entering a confined space (such as sewage tank, manhole, septic tank, etc.) must follow the confined spaces rules and regulations. This can be found in Code of Federal Regulations Book 29, Section 1910.146, distributed by OSHA. This gives guidelines on how to safely enter tanks to make needed changes or repairs. **If possible, make all changes or repairs without entering the tank.**



Before beginning pump installation, unpack hardware to ensure all items needed to complete the installation are accounted for. Inspect station to see if additional items not supplied by Environment One will be needed to complete the job, such as plumbing hardware kit, replacement tank, special tools, electrical hardware, etc.

This is a sewage handling pump and must be vented in accordance with local plumbing codes. **This pump is approved for use in sewage applications that may be classified as**

- Class I, Division 1, Group D
- Intrinsically safe
- Certified by ETL to FM3600, 3610, 3615 and 3615.80 standards in accordance with National Electric Code, ANSI/NFPA 70. All piping and electrical systems must be in compliance with applicable local and state codes.

Safety Warnings

A **Caution** statement in this manual designates a situation that could cause equipment failure or damage. Follow the proper safety procedures as described in the instructions.

A **Warning** statement in this manual designates a situation that can cause bodily harm and/or equipment damage. Follow the proper safety procedures as described in the instructions.

Warning

- Thermally protected automatic reset motor will restart without warning after protector trips. Always disconnect motor from power supply before servicing.
- To reduce the risk of electrical shock, refer to instruction manual for proper installation.
- Substitution/modification of components may impair intrinsic safety.
- To prevent ignition of flammable or combustible atmospheres, disconnect all power sources before servicing.
- Never throttle output valve.

Caution

- To reduce the risk of electrical shock, install all electrical connections above top grade level of the sump or in a listed liquid-tight panel box.
- This unit has more than one power supply connection. Disconnect all power supplies before servicing.
- For use in Class I, Division 1, Group D hazardous (classified) location, as certified by ETL to Factory Mutual Standards
- Acceptable for outdoor use in a tank
- Designed and manufactured in accordance with UL 778 listing standard
- This explosionproof pump is to only be serviced by Environment One explosionproof-certified personnel. Unauthorized repairs may void warranty and hazardous location listing, as well as the safe operation of this product.

Pump Specifications

Manufactured by: Environment One Corporation	Manufactured in: Niskayuna, New York, USA
Series: Extreme Max Pressure: 80 psi HP: 1 Phase: 1	Model: DX Voltage: 240VAC Max Amperage: 8 T-Code: T3C

This is a sewage handling pump and must be vented in accordance with local plumbing codes. All piping and electrical systems must be in compliance with applicable local and state codes.

1. REMOVE PACKING

MATERIAL: The User Instructions must be given to the owner. Hardware supplied with the unit, if any, will be used at installation.

2. TANK INSTALLATION:

Lift the station using only the methods described on page 9, Lifting Instructions. The tank is supplied with a standard grommet for connecting the 4" DWV (4.50" outside diameter; SCH 40 std) incoming sewer drain. Other inlet types and sizes are optional (Caution: 4" DR-35 pipe has a smaller diameter and won't create a watertight joint with the standard grommet). Please confirm that you have the correct inlet before

continuing. If a concrete ballast is attached to the tank, lift only by the lifting eyes (rebar) embedded in the concrete. **Do not drop, roll, or lay tank on its side. This will damage the unit and void the warranty.**

(Fig. 1a) Excavate a hole to a depth so that the removable cover extends above the finished grade line. The grade should slope away from the unit. The diameter of the hole must be large enough to allow for a concrete anchor. Place the unit on a bed of gravel, naturally rounded aggregate, clean and free flowing, with particles not less than 1/8" or more than 3/4" in diameter. The concrete anchor is not optional. (See page 10 for specific requirements for your unit.)

The unit should be leveled and the wetwell filled with water to the bottom of the inlet to help prevent

the unit from shifting while the concrete is being poured. The concrete must be vibrated to ensure there are no voids.

If it is necessary to pour the concrete to a higher level than the inlet, the inlet must be sleeved with an 8" tube before pouring.

The station was shipped in two sections, requiring field assembly. See the included Field Joint Assembly Instructions for additional information.

3. INLET PIPE INSTALLATION:

Mark the inlet pipe 3-1/2" from the end to be inserted. Inlet pipe should be chamfered and lubricated with a soap solution. Lubricate the inlet grommet with soap solution as well. Insert the pipe into the grommet up to the 3-1/2" mark. Inspect to ensure the grommet has remained intact and in place.

4. DISCHARGE: The use of 1-1/4" PVC pressure pipe; Schedule 40 and polyethylene pipe SDR 11 or SDR 7 are recommended. If polyethylene is chosen, use compression type fittings to provide a smooth inner passage. E/One requires that an E/One Uni-Lateral assembly (E/One part number NB0184PXX or NC0193GXX) or E/One Redundant Check Valve (E/One part number PC0051GXX) be installed in the pipe lateral outside the home between the pump discharge and the street main on all installations. Never use a ball-type valve as a check valve. E/One recommends the valve be installed as close to the public right-of-way as possible. Check local codes for applicable requirements.

CAUTION: Redundant check valves on station laterals and anti-siphon/check valve assemblies on grinder pump cores should not be used as system isolation valves during line tests.

There is a ball valve and a quick disconnect pre-installed in the accessway. There is a 1-1/4" female NPT discharge connection

Figure 2

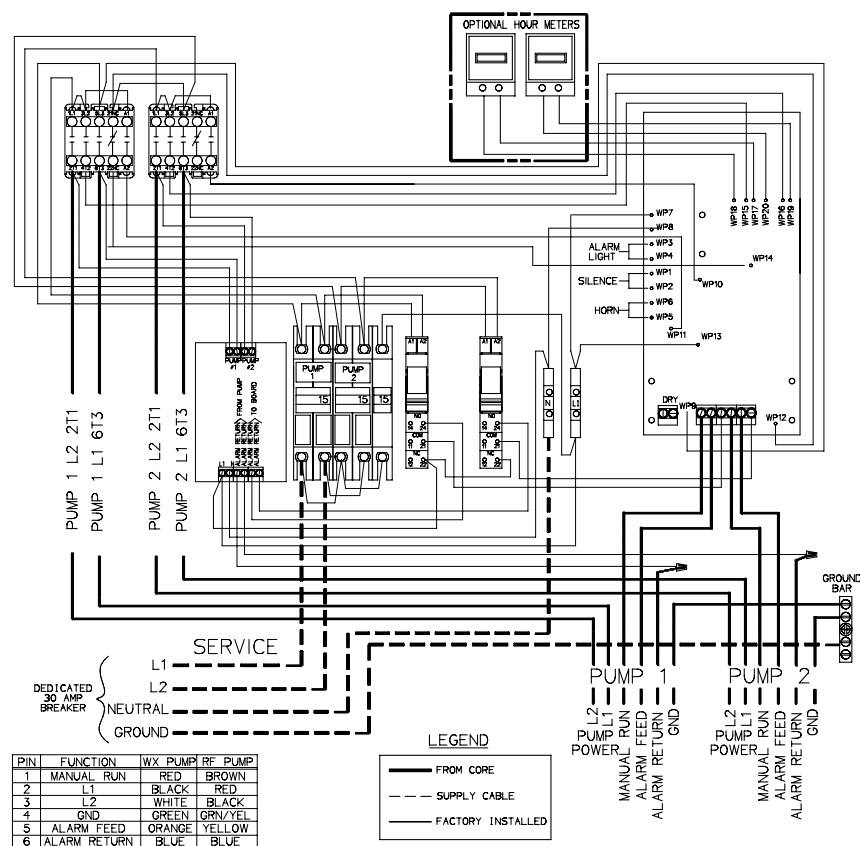

240 VOLT DUPLEX WIRING

on the outside of the tank 41" above the bottom of the tank.

5. BACKFILL REQUIREMENTS: Proper backfill is essential to the long term reliability of any underground structure. Several methods of backfill are available to produce favorable results with different native soil conditions.

The recommended method of backfilling is to surround the unit to grade using Class I or Class II backfill material as defined in ASTM 2321. Class 1A and Class 1B are recommended where frost heave is a concern; Class 1B is a better choice when the native soil is sand or if a high, fluctuating water table is expected. Class I, angular crushed stone, offers an added benefit in that it needs minimal compaction. Class II, naturally rounded stone, may require more compactive effort, or tamping, to achieve the proper density.

If the native soil condition consists of clean compactible soil, with less than 12% fines, free of ice, rocks, roots, and organic material, it may be an acceptable backfill. Such soil must be compacted in lifts not to exceed one foot to reach a final Proctor Density between 85% and 90%. Non-compactible clays and silts are **not** suitable backfill for this or any underground structure such as inlet or discharge lines. If you are unsure of the consistency of the native soil, it is recommended that a geotechnical evaluation of the material be obtained before specifying backfill.

Another option is the use of a flowable fill (i.e., low slump concrete). This is particularly attractive when installing grinder pump stations in augured holes where tight clearances make it difficult to assure proper backfilling and compaction with dry materials. Flowable fills should not be dropped with more than 4 feet between the discharge nozzle and the bottom of the hole because

this can cause separation of the constituent materials.

If the station is buried too low, increasing station height by 6 inches can be done without cutting the station. Use the E/One Extender cover shroud kit (ND0082G01) and follow the instructions that are included with the kit.

6. VENTING: The unit must be properly vented to assure correct operation of the pump. The unit is supplied with a vent pipe from the wetwell to the top of the accessway. Failure to *properly vent* the tank will result in faulty operation and will void the warranty.

7. ELECTRICAL CONNECTION: (Supply panel to E/One Alarm Panel) Before proceeding, verify that the service voltage is the same as the motor voltage shown on the name plate. An alarm device is to be installed in a conspicuous location where it can be readily seen. An alarm device is required on every installation. There shall be no exceptions.

Refer to the wiring instructions provided with the purchased panel

for proper wiring connections and operation information. A dedicated 30 amp breaker is required before a 240V duplex alarm panel. Electrical installation must follow NEC 70-501 code and local codes for Explosionproof Class I, Division 1, application.

****IMPORTANT:** *The Equalizer should be hung as high in the station as possible to ensure that the pump functions properly. Do not leave the excess cable in the station.*

8. ELECTRICAL CONNECTION: (Pump to Panel) Wiring between the station and the panel must comply with NEC 70 section 501 (for Hazardous Location Class I, Div 1) and all local codes.

The station is provided with a flat surfaced fitting 24" down from grade, over the inlet. This fitting is shipped solid from the factory and will need to be drilled out to the desire size to fit the conduit fitting. The penetration must be made in the center of the fitting; doing so, you will be able to make penetrations up to 3.5". When the installation of the conduit is complete, the installer

Figure 3

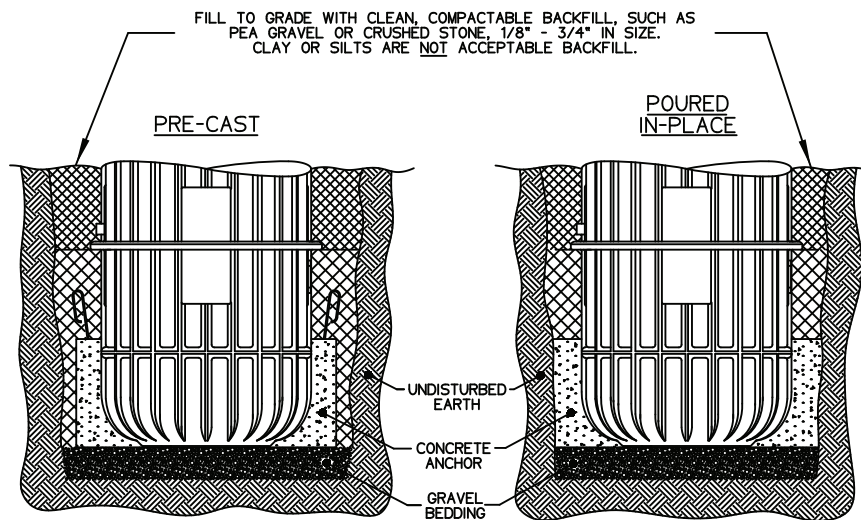

TYPICAL IN-GROUND SECTION VIEW

Pump Cable Wire Color Table

Wire Color	Function
Red	Manual Run (common to L1)
Black	L1
White	L2
Green	Ground
Orange	Alarm Switch Feed
Blue	Alarm Switch Return
White/Black Strip	Not Connected, Unused

must ensure all connections are watertight. For a DX152-93, the conduit connector, provided by others, is to be installed in the flat surface on the drywell, directly above the inlet (Fig. 1b).

Conduit used must be per NEC 70 section 501.A.1, RMC or IMC Threaded conduit. All joints must be watertight. No splices of any kind can be made before a seal-off fitting. Any wire connections or splices made before the alarm panel must be watertight to prevent shorting.

Depending on location, the conduit burial depth can be as shallow as 6 inches; refer to NEC 70 section 300.5.

The standard length of cable attached to the pump from the factory is 75 feet. The cable is 14 gauge; longer lengths are a problem due to voltage drop. The maximum voltage drop allowed at the pump is 10% of nameplate (a 240 volt pump can be no less the 216 volts, while pump in operating). If longer lengths are necessary, contact the factory for alternative wiring methods.

9. DEBRIS REMOVAL: Prior to start-up test procedure, the pump must be removed and the incoming sewer line flushed to force all miscellaneous debris into the tank. Next, all liquid and debris must be removed. Once the tank is clean, reinstall the pump and proceed with the test.

10. TEST PROCEDURE: When the system is complete and ready for use, the following steps should be taken to verify proper pump and high level alarm operation:

a) Make sure that the discharge shutoff valve is fully open. This valve must not be closed when the pump is operating. In some installations there may be a valve, or valves, at the street main that must also be open.

(Ignore all Trouble indications, LEDs and/or messages until the panel is reset at the end of this procedure.)

b) Fill tank with 100 gallons of water.

c) Turn on pump and alarm breakers; the pump and high level alarm should turn on immediately.

d) Verify that the high level alarm turns off and then the pump turns off.

e) Clear/Reset the alarm panel:
Protect Panel: Turn pump and alarm breakers off and back on simultaneously.

Protect Plus Panels: Perform a "cold start" from the Initialize System menu. Any user setting that were previously chosen will not be reset.

f) If any Trouble or alarm conditions are indicated after the panel is reset, contact your local service provider.

Field Joint Assembly Instructions

IT IS EXTREMELY IMPORTANT THAT THE JOINT IS SEALED PROPERLY BEFORE BACKFILLING. EXCAVATING A UNIT FOR REPAIR IS VERY EXPENSIVE AND CAN BE EASILY AVOIDED BY USING PROPER CAUTION DURING THE FOLLOWING PROCEDURE.

Parts included in Field Joint Kit:
Identify all parts before proceeding with installation.

- (16) 3/8-16 x 1-1/2 long screws
- (16) 3/8-16 Elastic Stop Nuts
- (32) Flat Washers
- (1) Length Sealant (Sika) Tape
- (1) Hole Punch
- (1) Vent Pipe Extension

1) Carefully clean and dry both accessway flanges with solvent. **IMPORTANT: Sealing surfaces must be dry to ensure the sealant adheres correctly.**

2) Starting at one hole of tank flange, apply two layers of Sika Tape around the inside half of the flange. Align the outside edge of the tape with the bolt circle. Move to the adjacent hole and apply one layer of Sika Tape around the outside of the flange. Align inside of tape with the bolt circle. Remove the backing paper as you lay the adhesive on the flange.

Do not stretch Sika tape during application; it may result in a leak. The tape should overlap at the end by approximately 1/2 inch, as shown in Fig. 5a. If a section of Sika Tape is misapplied, the bad section may be cut out and replaced. Cut away the poorly laid portion cleanly with a knife and be sure to overlap the tape at each end about 1/2 inch.

3) Using the tool provided, punch a hole through the tape at each of the 16 existing bolt holes in the flange. **Be careful to keep the exposed sealant clean and dry.**

4) Insert three of the sixteen 3/8-16 x 1-1/2" long bolts, with a flat washer, into the flange attached to the upper part of the accessway. These will act as guides while

aligning the bolt pattern of the two flanges.

5) Support the upper accessway section a few inches over the tank, making sure to align the vent port in the lid with the vent pipe in the tank. Once aligned, lower the upper section onto the mating flange using the three bolts to guide it to the proper position. See Fig. 5b.

6) Insert the remaining 13 bolts with flat washers into the flanges. Place a flat washer and elastic stop nut on the end of each bolt, turning the nut on just enough to hold the washer in place.

7) Tighten the bolts until the sealant begins to squeeze out from between the flanges. To ensure a consistent, sturdy seal, tighten them in the following sequence: 1, 9; 5, 13; 3, 11; 7, 15; 2, 10; 4, 12; 6, 14; 8, 16. Always be sure to tighten one bolt and then the bolt at the position 180° from it; see Fig. 1 for position

numbers.

8) Using the same sequence as in Step 7, tighten each bolt to 60 in-lbs. Visually inspect the joint, each bolt and each nut should have a flat washer between it and the flange, and a uniform amount of sealant should be protruding from the seam along the entire perimeter.

In the event that there are any voids in the sealant, the joint may leak. Take corrective actions if necessary and be sure that the joint is leak free before continuing.

9) Install the vent pipe extension piece, which was shipped inside the upper piece of the accessway. Push the extension pipe into the bell mouth fitting on the pipe installed in the wet well tank. Be sure the pipe is seated correctly. Slide the top end of the extension pipe into the receptacle on the bottom of the lid.

Figure 5a

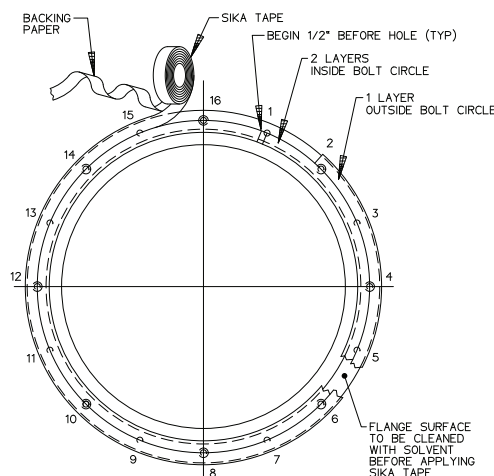
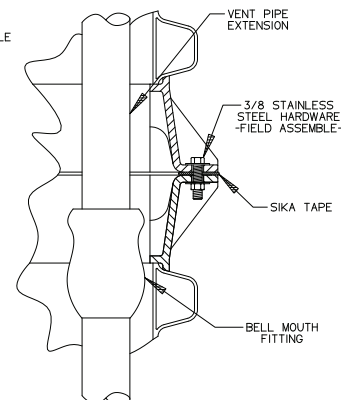

Figure 5b



Lifting Instructions

FAILURE TO FOLLOW THESE INSTRUCTIONS COMPLETELY WILL VOID WARRANTY.

* Transporting unit to installation site: **Always lift a unit from the bottom for the purpose of transportation. The station should be received attached to a pallet for this purpose.** Never roll a station or move it on its side.

1. No ballast, no eye bolts (ballast to be poured in place): If the concrete anchor is to be poured while the station is in place and it has no eye bolts, lift the unit by securing two 20-foot flat or round eye slings around the station. Loop the slings around the station and use an appropriate lifting beam or tie-down strap to ensure the safety of the station and people close to the unit.

2. No ballast, factory-installed eye bolts (ballast to be poured in place): If the concrete anchor is to be poured while the station is in place lift the unit by securing straps to the eyebolts supplied on the lower flange, as shown below. Keep station oriented vertically to avoid any damage. Only lift from the eyebolts to put unit in hole, not for moving any distance.

3. Precast ballast: Never lift a station that has a ballast attached by any means except the rebar hooks. The weight of the concrete will damage the station if you attempt to lift it from any part of the station.

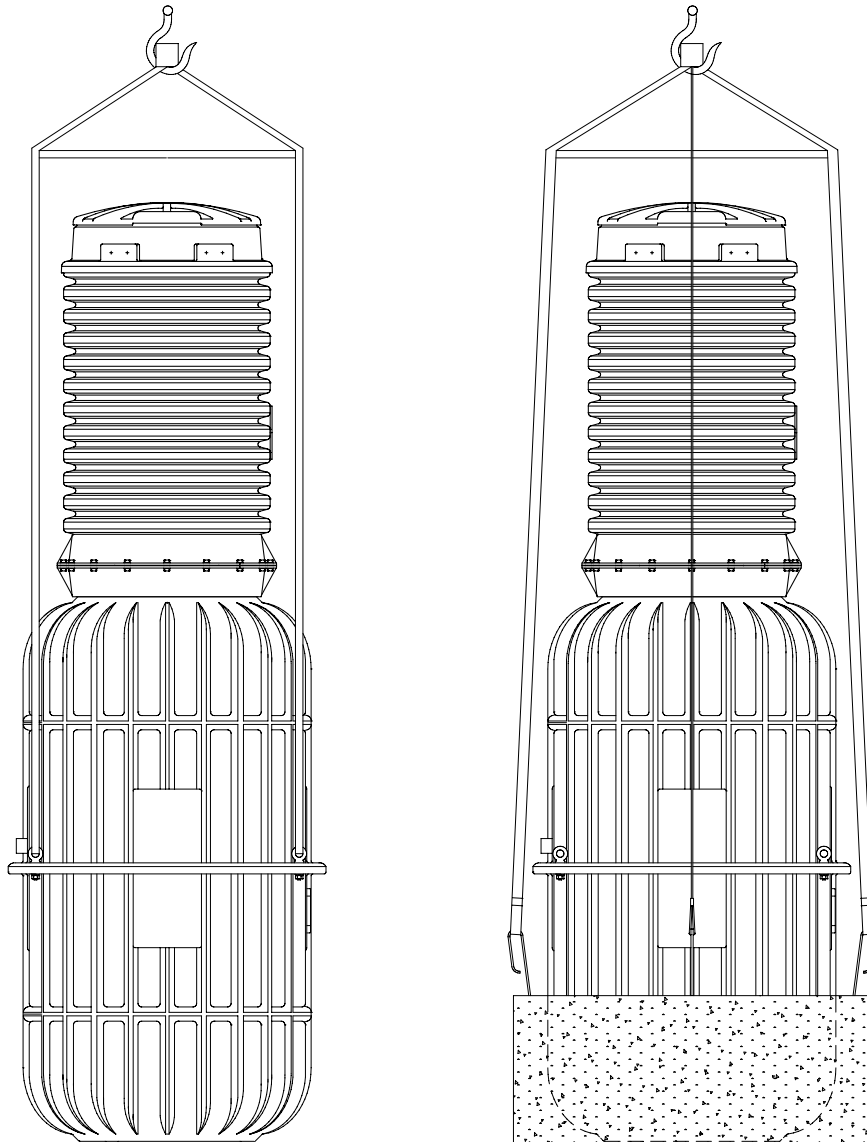

E/One Grinder Pump Station Ballast Calculations

Any buried vessel that is submerged, or partially submerged, in water will be acted on by an upward buoyant force that attempts to return the vessel to a non-submerged state. The magnitude of this buoyant force is equal to the volume of the vessel that is submerged multiplied by the density of water. On most in-ground installations a ballast, or concrete anchor, of proper volume and weight is required to resist the buoyant force. The amount of ballast required for a given set of installation site conditions may be calculated as follows.

BALLAST WORKSHEET DX152

Model	Pump Volume * (ft ³)	Pump Height (ft)	Pump Dia. (ft)	Submerged Volume (ft ³)	Buoyant Force (lbs.)	Pump Weight (lbs.) *	Net Buoyant Force (lbs.)	Ballast Height (in.)	Ballast Diameter (in)	Area of Ballast (ft ²)
DX152-129	61.0	10.77	3.07	61.00	3806	609	3197	23	48	5.16
DX152-160	71.0	13.39	3.07	71.00	4430	639	3791	23	48	5.16

Model	Volume of Ballast (ft ³)	Volume of Ballast (yd ³)	Weight (in water) of Concrete (lb)	Weight (in air) of Concrete (lb)	Volume of Saturated Soil (ft ³)	Weight of Saturated Soil (lb)	Total Ballast Weight (lb)	Final Condition Weight (lb)
DX152-129	9.9	0.4	867.0	1485	44.3	3100.9	3968.0	770.6
DX152-160	9.9	0.4	867.0	1485	57.8	4048.0	4915.1	1123.7

Notes:

1. These calculations assume ground water at grade
2. The assumed weight of saturated soil in these calculations is 70lb/ft³

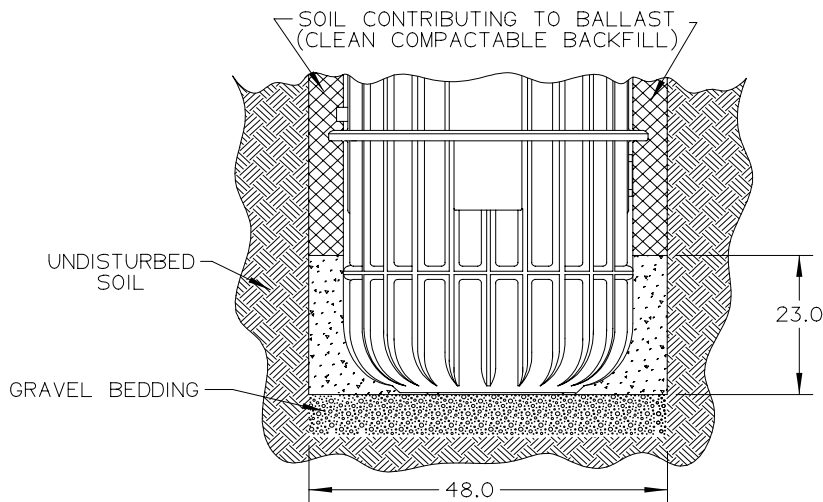



A Precision Castparts Company

Environment One Corporation
2773 Balltown Road
Niskayuna, New York 12309-1090

Voice: 518.346.6161
Fax: 518.346.6188

www.eone.com

NA0206P01 Rev F
10/19

User Instructions for the Environment One Grinder Pump

General Information

Your home is served by a low pressure sewer system; the key element is an Environment One grinder pump. The tank collects all solid materials and wastewater from the house. The solid materials are then ground to a small size suitable for pumping as a slurry with the wastewater. The grinder pump generates sufficient pressure to pump this slurry from your home to the wastewater treatment receiving line and/or disposal plant.

This device complies with Part 15 of the FCC rules. Operation is subject to the following two conditions: 1) this device may not cause harmful interference; and 2) this device must accept any interference received, including interference that may cause undesired operation. Any changes or modifications not expressly approved by the party responsible for compliance could void the user's authority to operate this equipment.

Care and Use of your Grinder Pump

The Environment One grinder pump is capable of accepting and pumping a wide range of materials, and an extensive grind test is required in order to obtain NSF approval. However, regulatory agencies advise that the following items should not be introduced into any sewer, either directly or through a kitchen waste disposal unit:

Glass	Seafood shells	Diapers, socks, rags or cloth	Syringes
Cotton swabs	Personal/cleaning wipes & sponges	Disposable toothbrushes	Latex/vinyl items
Metal	Plastic objects (toys, utensils, etc.)	Kitty litter	Dental floss
Aquarium gravel	Sanitary napkins or tampons	Cigarette butts	

Caution: Kitchen garbage disposals do not keep grease/oil out of the plumbing system

In addition, you must **never** introduce into any sewer:

Explosives	Strong chemicals	Lubricating oil and/or grease
Flammable material	Gasoline	

Items introduced into the sewer system from your home can potentially impact the water environment. Proper disposal of household wastes such as window cleaners, unused/expired pharmaceuticals, paint thinners, fats, fruit labels, etc. is important. For more information, visit <http://www.wef.org>.

Periods of Disuse

If your home or building is left unoccupied for longer than a couple of weeks, perform the following procedure:

Purge the System. Run clean water into the unit until the pump activates. Immediately turn off the water and allow the grinder pump to run until it shuts off automatically.

Duplex Units. Special attention must be taken to ensure that both pumps turn on when clean water is added to the tank.

Caution: Do not disconnect power to the unit

Power Failure

Your grinder pump cannot dispose of wastewater without electrical power. If electrical power service is interrupted, keep water usage to a minimum.

Pump Failure Alarm

Your Environment One grinder pump has been manufactured to produce an alarm signal (120 volt) in the event of a high water level in the basin. The installer must see that the alarm signal provided is connected to an audible and/or visual alarm in such a manner as to provide adequate warning to the user that service is required. During the interim prior to the arrival of an authorized service technician, water usage must be limited to the reserve capacity of the tank.

For service, please call your local distributor:



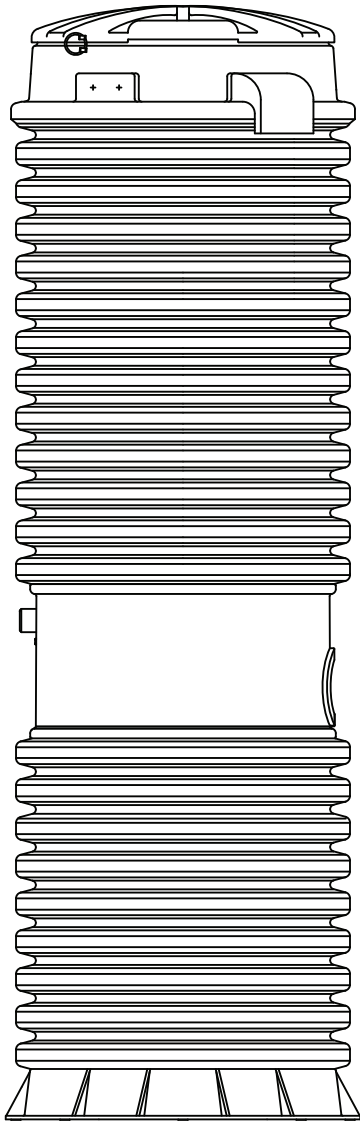

Limited Warranty

For Model DX
Grinder Pump Stations

Environment One Corporation offers a limited warranty that guarantees its product to be free from defects in material and factory workmanship for a period of two years from the date of installation, or 27 months from the date of shipment, whichever occurs first, provided the product is properly installed, serviced and operated under normal conditions and according to manufacturer's instructions. Repair or parts replacement required as a result of such defect will be made free of charge during this period upon return of the defective parts or equipment to the manufacturer or its nearest authorized service center.

Model Number: _____

Serial Number: _____

Installation Date: _____



2773 Balltown Rd • Niskayuna NY USA 12309
518.346.6161 • www.eone.com