

DH151/DR151

General Features

The model DH151 or DR151 grinder pump station is a complete unit that includes: the grinder pump, check valve, polyethylene tank, controls, and alarm panel. A single DH151 or DR151 is a popular choice for up to two, average single-family homes and can also be used for up to six average single-family homes where codes allow and with consent of the factory.

- Rated for flows of 1500 gpd (5678 lpd)
- 150 gallons (568 liters) of capacity
- Indoor or outdoor installation
- Standard outdoor heights range from 63 inches to 160 inches

The DH151 is the “hardwired,” or “wired,” model where a cable connects the motor controls to the level controls through watertight penetrations.

The DR151 is the “radio frequency identification” (RFID), or “wireless,” model that uses wireless technology to communicate between the level controls and the motor controls.

Operational Information

Motor

1 hp, 1,725 rpm, high torque, capacitor start, thermally protected, 120/240V, 60 Hz, 1 phase

Inlet Connections

4-inch inlet grommet standard for DWV pipe. Other inlet configurations available from the factory.

Discharge Connections

Pump discharge terminates in 1.25-inch NPT female thread. Can easily be adapted to 1.25-inch PVC pipe or any other material required by local codes.

Discharge

15 gpm at 0 psig (0.95 lps at 0 m)
11 gpm at 40 psig (0.69 lps at 28 m)
7.8 gpm at 80 psig (0.49 lps at 56 m)

Accessories

E/One requires that the Uni-Lateral, E/One’s own stainless steel check valve, be installed between the grinder pump station and the street main for added protection against backflow.

Alarm panels are available with a variety of options, from basic monitoring to advanced notice of service requirements.

The Remote Sentry is ideal for installations where the alarm panel may be hidden from view.

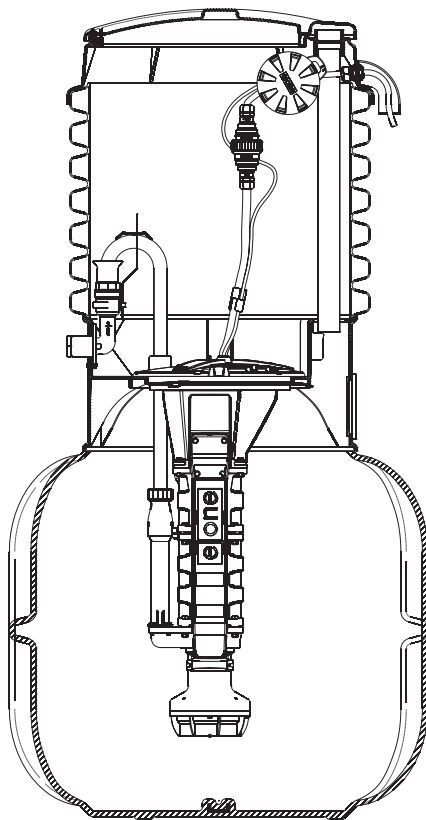

FIELD JOINT REQUIRED
FOR MODELS
DH151-129 / DR151-129
&
DH151-160 / DR151-160

OPTIONS: DH151 (HARD WIRED LEVEL CONTROLS)
 DR151 (WIRELESS LEVEL CONTROLS)

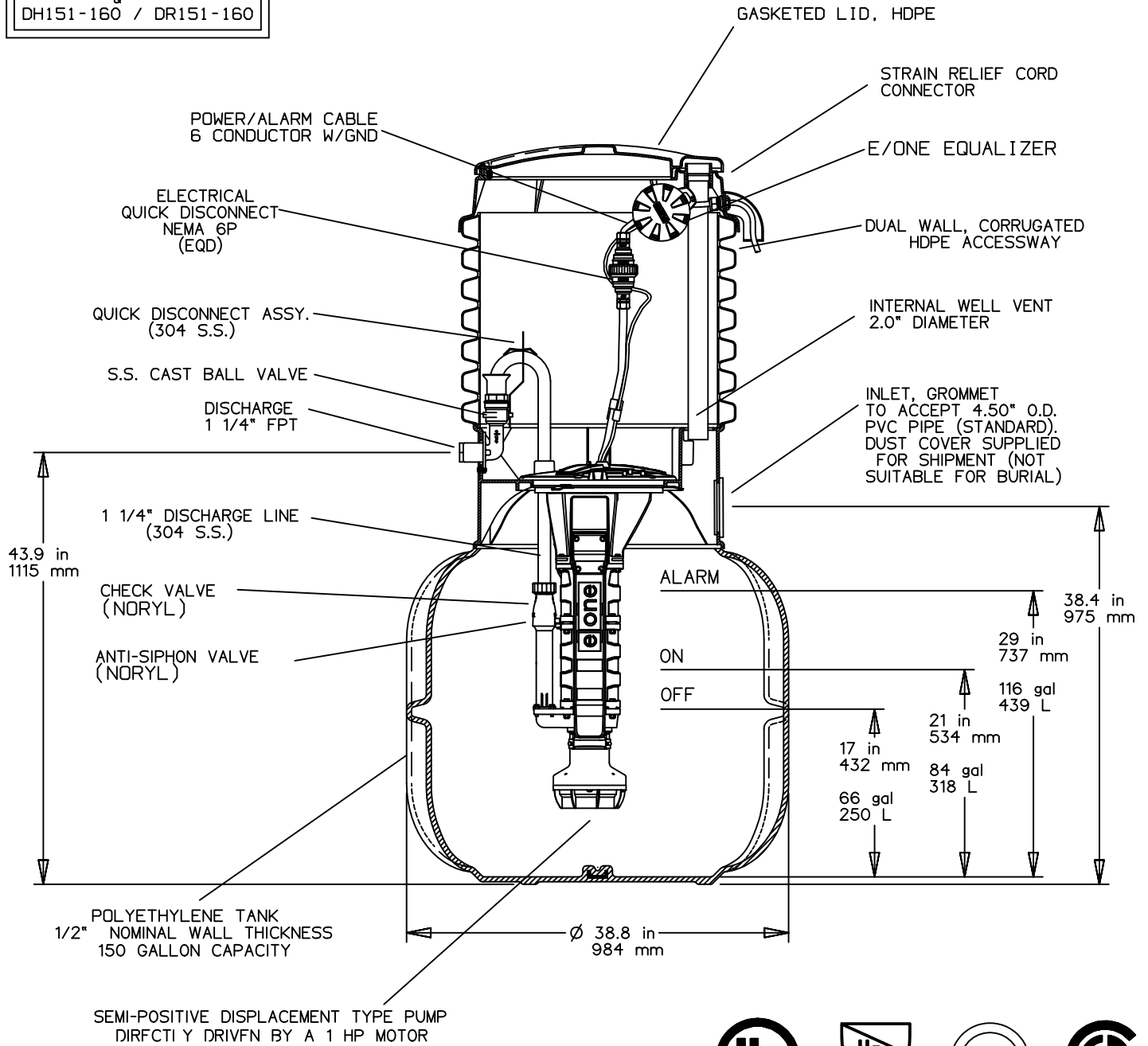

CONCRETE BALLAST MAY BE REQUIRED
SEE INSTALLATION INSTRUCTIONS
FOR DETAILS

NOTE: DIMENSIONS ARE FOR REFERENCE ONLY

KC	PD	09/30/19	F	
DR BY	CHK'D	DATE	ISSUE	SCALE
 SEWER SYSTEMS				
MODEL DH151 / DR151 DETAIL SHEET				
NA0051P02				

DH151-47 INDOOR UNIT

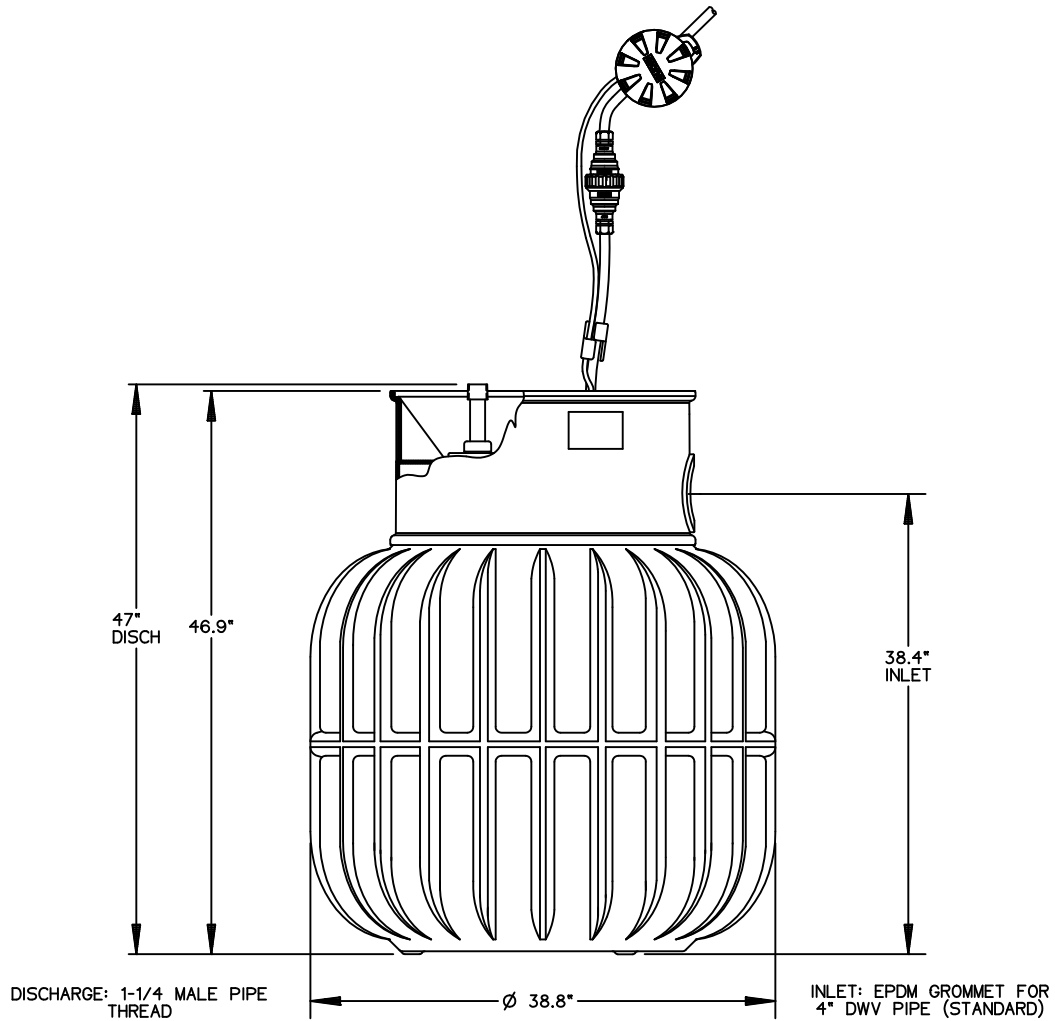

NOTE: DIMENSIONS ARE FOR REFERENCE ONLY



LNT	GAE	04/24/07	B	
DR BY	CHK'D	DATE	ISSUE	SCALE
MODEL DH151-47				
NA0051P03				

OPTIONS : **DH151-63** (HARD WIRED LEVEL CONTROLS)
 DR151-63 (WIRELESS LEVEL CONTROLS)

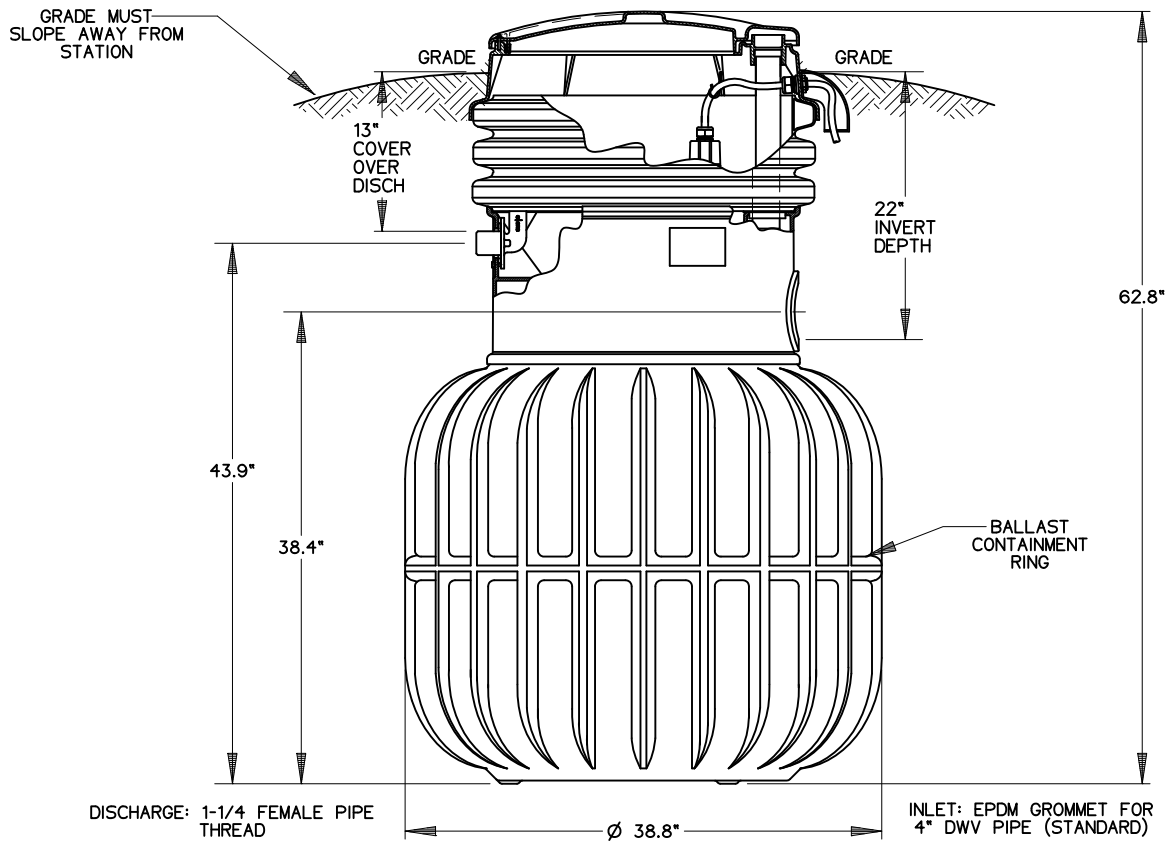

CONCRETE BALLAST MAY BE REQUIRED
 SEE INSTALLATION INSTRUCTIONS
 FOR DETAILS

NOTE: DIMENSIONS ARE FOR REFERENCE ONLY

AD	CAH	07/13/07	C	1/16
DR BY	CHK'D	DATE	ISSUE	SCALE



MODEL DH151-63 / DR151-63

NA0051P04

OPTIONS :

DH151-74

(HARD WIRED
LEVEL CONTROLS)

DR151-74

(WIRELESS
LEVEL CONTROLS)

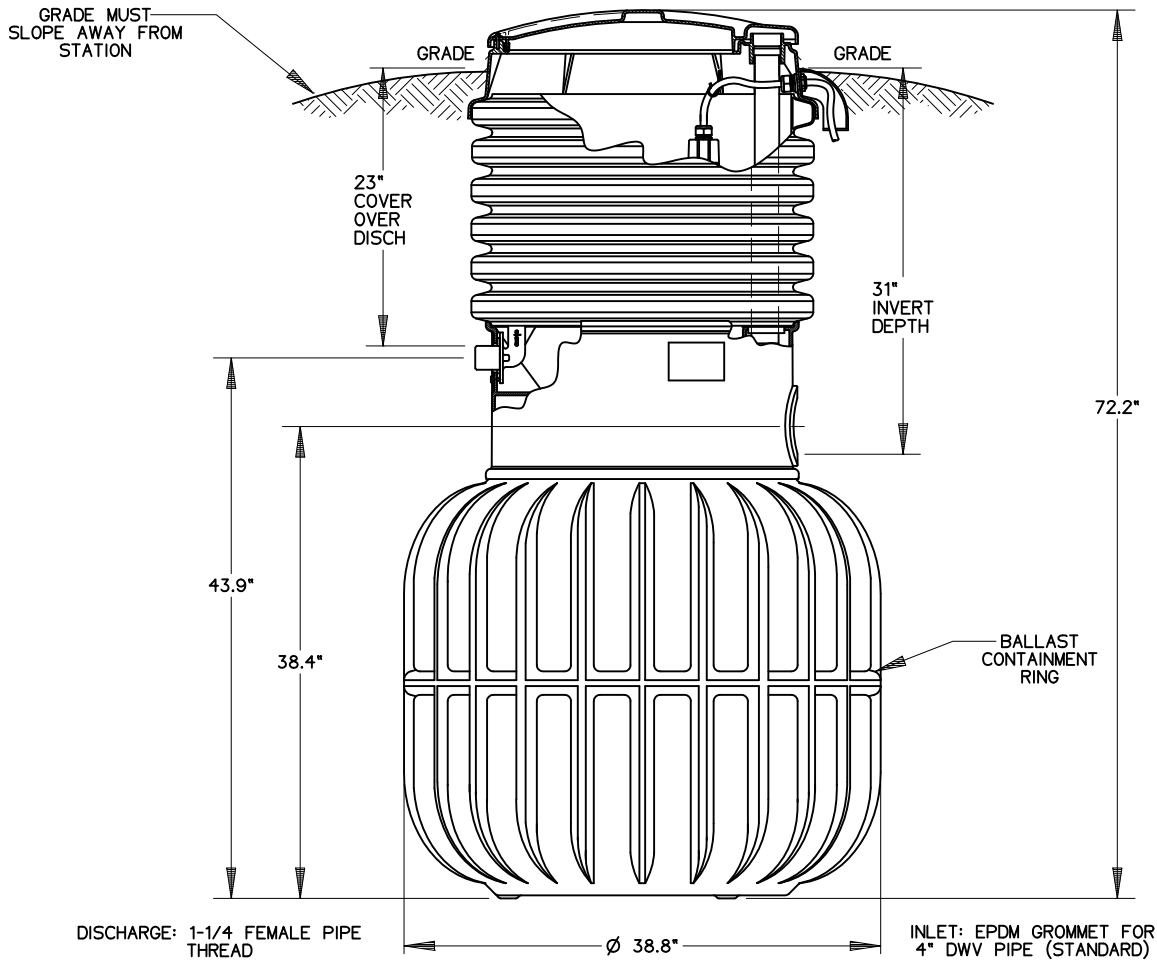

CONCRETE BALLAST MAY BE REQUIRED
SEE INSTALLATION INSTRUCTIONS
FOR DETAILS

NOTE: DIMENSIONS ARE FOR REFERENCE ONLY

AD	CAH	07/13/07	D	1/16
DR BY	CHK'D	DATE	ISSUE	SCALE



MODEL DH151-74 / DR151-74

NA0051P05

OPTIONS : **DH151-93** (HARD WIRED LEVEL CONTROLS)
 DR151-93 (WIRELESS LEVEL CONTROLS)

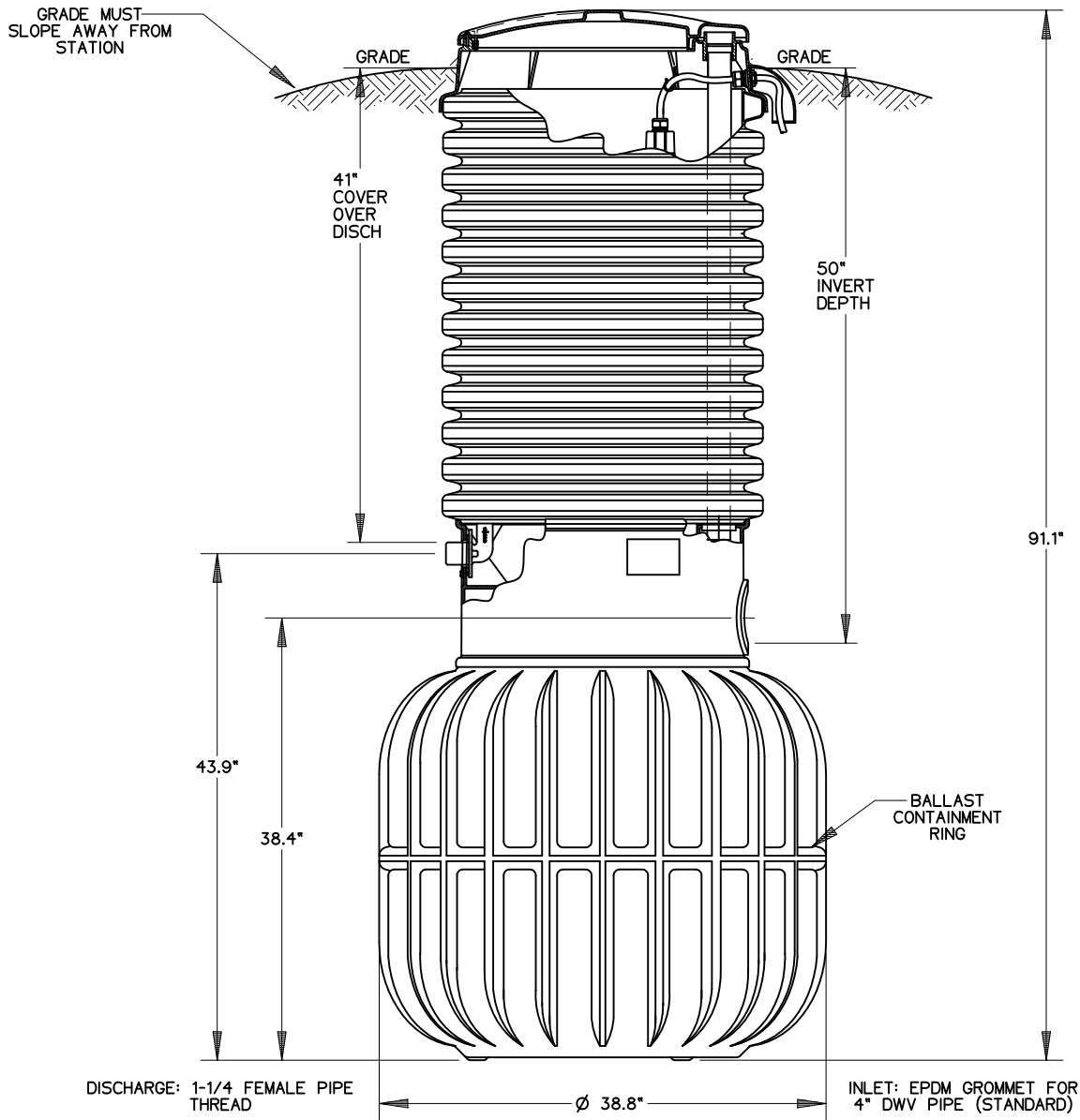

CONCRETE BALLAST MAY BE REQUIRED
 SEE INSTALLATION INSTRUCTIONS
 FOR DETAILS

NOTE: DIMENSIONS ARE FOR REFERENCE ONLY



AD	CAH	7/13/07	D	1/16
DR BY	CHK'D	DATE	ISSUE	SCALE
MODEL DH151-93 / DR151-93				
NA0051P06				

OPTIONS : **DH151-129**

(HARD WIRED
LEVEL CONTROLS)

DR151-129

(WIRELESS
LEVEL CONTROLS)

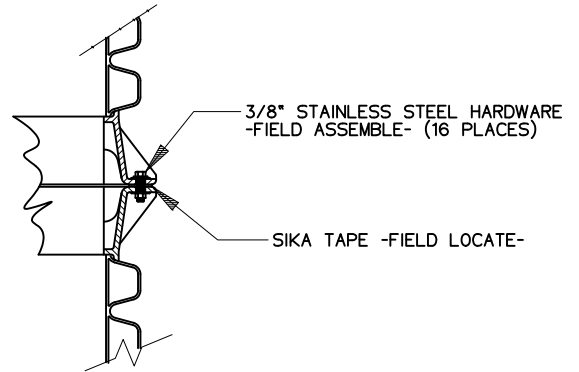
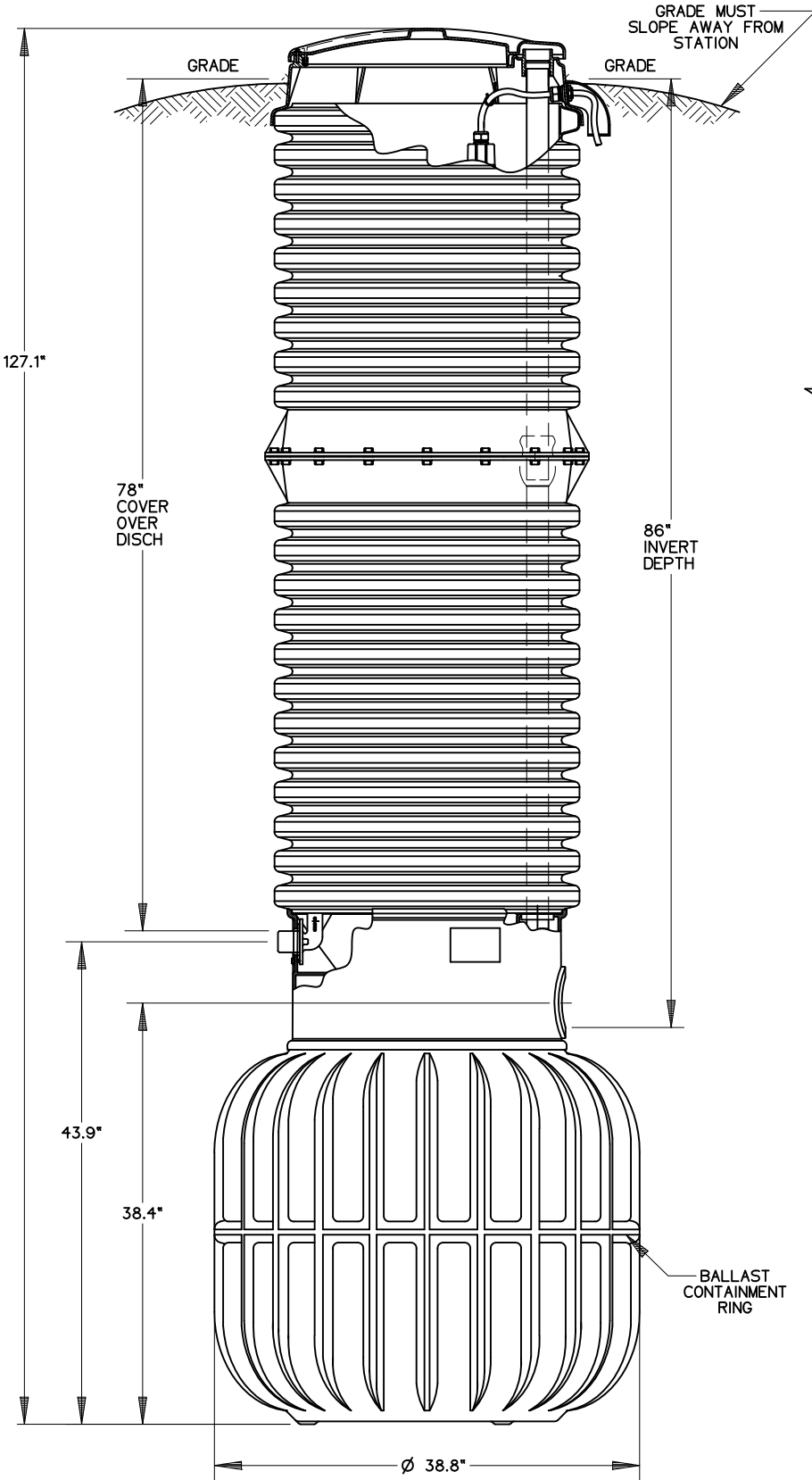

DETAIL, FIELD JOINT

SEE INSTALLATION INSTRUCTIONS FOR FURTHER DETAILS

CONCRETE BALLAST MAY BE REQUIRED
SEE INSTALLATION INSTRUCTIONS FOR DETAILS



AD	CAH	07/13/07	D	1/16
DR BY	CHK'D	DATE	ISSUE	SCALE



MODEL DH151-129 / DR151-129

NA0051P07

NOTE: DIMENSIONS ARE FOR REFERENCE ONLY

OPTIONS : **DH151-160**

(HARD WIRED
LEVEL CONTROLS)

DR151-160

(WIRELESS
LEVEL CONTROLS)

GRADE MUST
SLOPE AWAY FROM
STATION

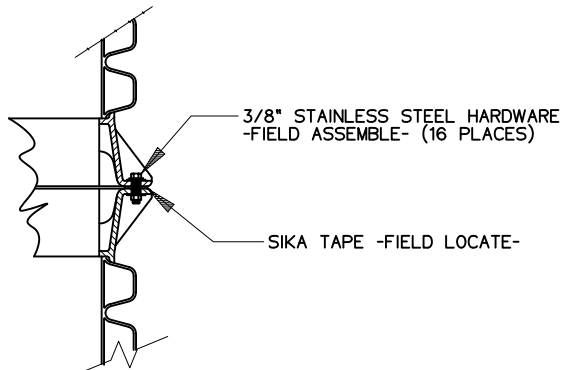
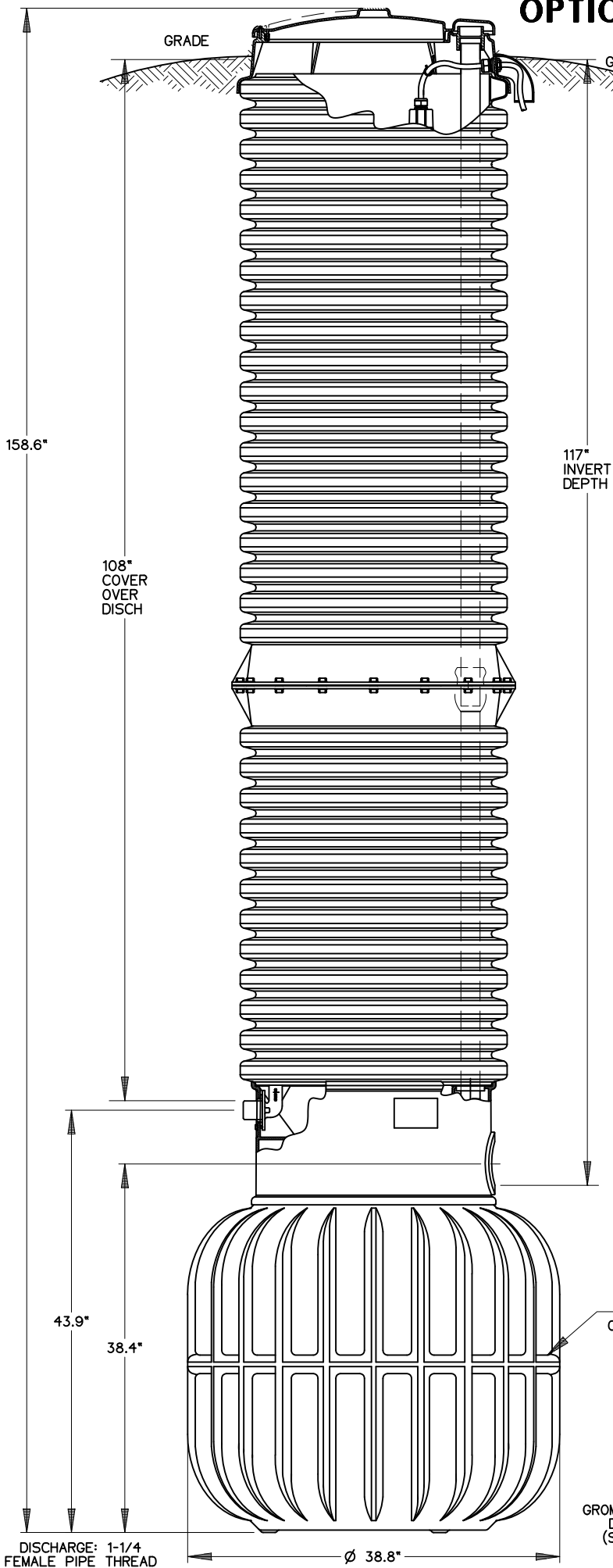

DETAIL, FIELD JOINT

SEE INSTALLATION INSTRUCTIONS FOR FURTHER DETAILS

CONCRETE BALLAST MAY BE REQUIRED
SEE INSTALLATION INSTRUCTIONS FOR DETAILS

NOTE: DIMENSIONS ARE FOR REFERENCE ONLY



AD	CAH	7/13/07	D	1/16
DR BY	CHK'D	DATE	ISSUE	SCALE



MODEL DH151-160 / DR151-160

NA0051P08

DH151-59

BUILDERS MODEL

STRAIGHT DISCHARGE

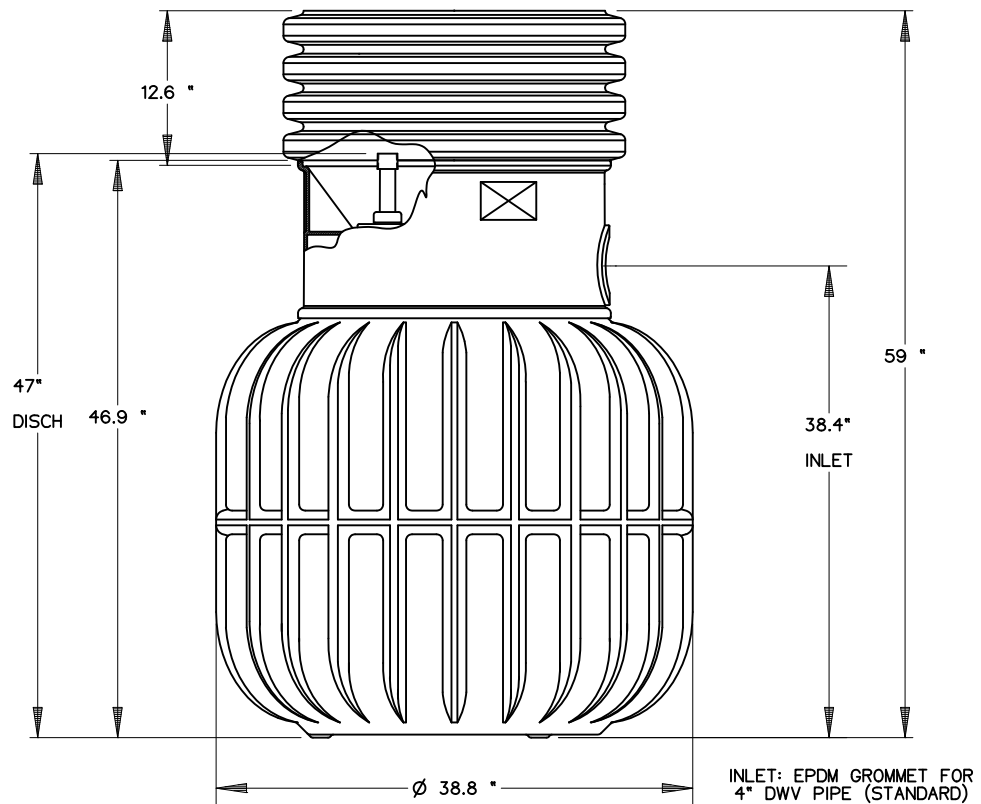

AD	CAH	06/27/07	C	1/16
DR BY	CHK'D	DATE	ISSUE	SCALE



MODEL DH151-59
BUILDERS

NA0051P09

NOTE: DIMENSIONS ARE FOR REFERENCE ONLY

DH151-59

BUILDERS MODEL

OUTSIDE TYPE DISCHARGE

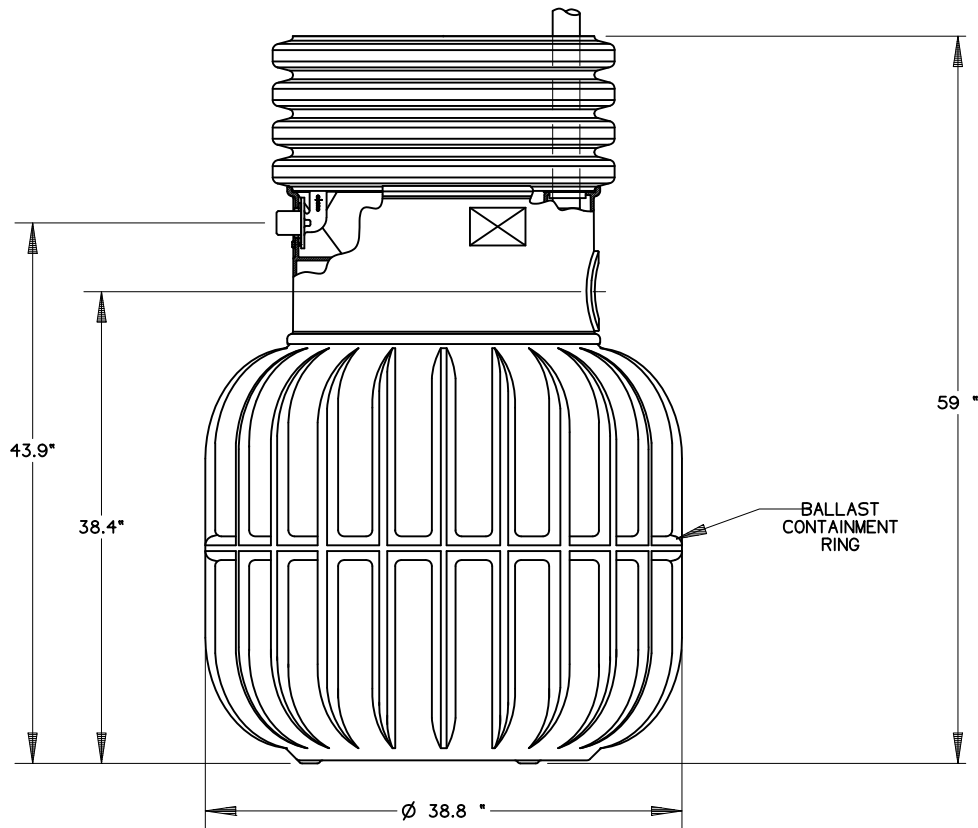

AD	CAH	06/27/07	C	1/16
DR BY	CHK'D	DATE	ISSUE	SCALE
 SEWER SYSTEMS				
MODEL DH151-59 BUILDERS				
NA0051P10				

NOTE: DIMENSIONS ARE FOR REFERENCE ONLY