

# PACK JOINT INSTRUCTIONS

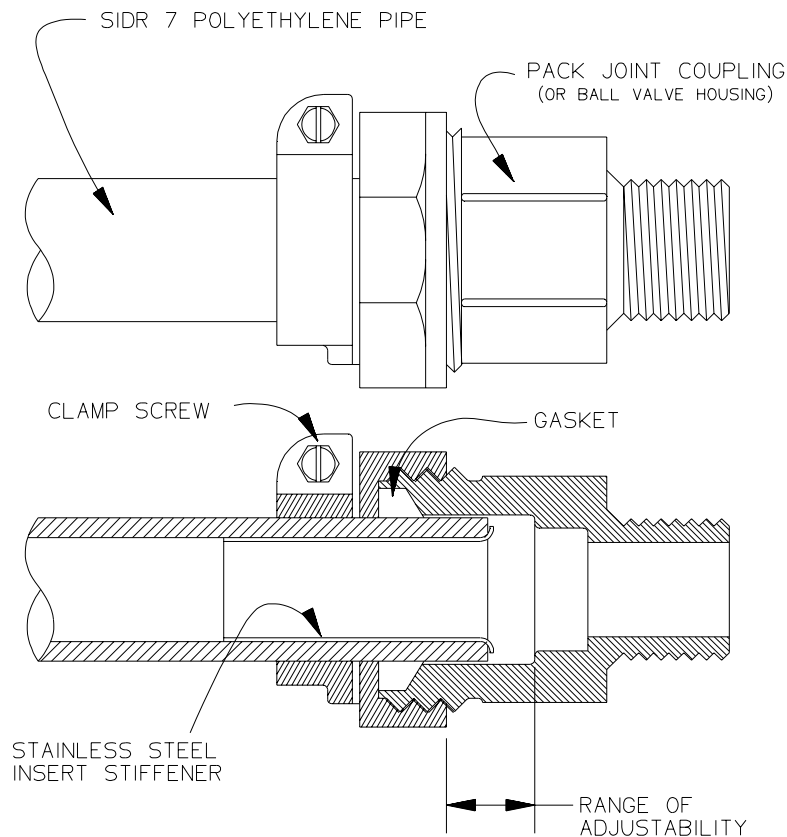

## INSTALLATION STEPS

- 1- CUT PIPE SQUARE.
- 2- MAKE SURE PIPE IS ROUND, NOT FLATTENED. CLEAN OFF ANY DIRT SO THAT THE SURFACE IS SMOOTH.
- 3- INSERT STIFFENER INTO THE END OF PIPE. PRESS STIFFENER IN UNTIL THE ROLLED RIB BUTTS UP TO THE END OF THE PIPE.
- 4- INSERT PIPE THROUGH PACK JOINT NUT AND INTO THE SOCKET OF THE FITTING.
- 5- TIGHTEN PACK JOINT NUT 1 TO 1-1/2 TURNS AFTER GASKET STARTS TO COMPRESS.
- 6- TIGHTEN THE CLAMP SCREW VERY SECURELY WITH A SOCKET OR BOX END WRENCH.

## PRECAUTIONS

- 1- ALWAYS PRESSURE TEST FOR LEAKS PRIOR TO BACKFILLING.
- 2- BRASS FITTINGS CAN BE DAMAGED BY IMPROPER HANDLING. PROTECT THREADS. DO NOT DROP. BACKFILL AND COMPACT CAREFULLY PER ASTM D2321 SO THAT FITTINGS ARE NOT STRESSED BY THE WEIGHT OF THE EARTH.
- 3- PROTECT BALL VALVE ASSEMBLIES FROM FREEZING. ATTEMPTING TO FORCIBLY OPEN OR CLOSE A FROZEN VALVE WILL DESTROY THE VALVE.

APS	CAH	01/10/02	B	2/5
DR BY	CHK'D	DATE	ISSUE	SCALE

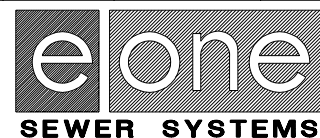

PACK JOINT INSTRUCTIONS

PA1333P02