

GP 1012s

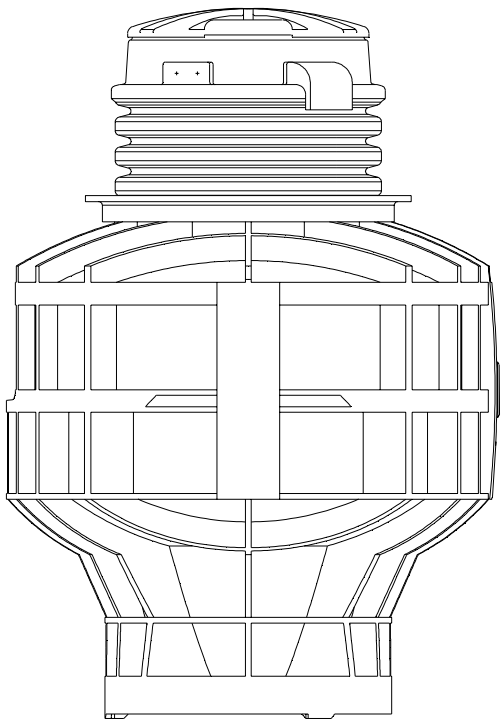

General Applications

The size, efficiency and operating economy of the GP 1012s make it your best choice for single dwellings, waterfront property, subdivision developments and marinas. The GP 1012s is ideally suited for both new and existing communities.

Features

The GP 1012s is a complete unit that includes: the grinder pump, check valve, polyethylene tank and controls.

All solids are ground into fine particles, allowing them to pass easily through the pump, check valve, and small diameter pipe lines. Even objects that are not normally found in sewage, such as plastic, rubber, fiber, wood, etc. are ground into fine particles.

The 1-1/4" inch discharge connection is adaptable to any piping materials, thereby allowing us to meet your local code requirements.

The tank is made of tough corrosion-resistant polyethylene. Designed specifically for low pressure sewer applications, the 1012s has an optimum tank capacity of 237 gallons, providing ample user storage. The lower portion of the tank has a smaller diameter tapered down to a dish shaped bottom. These design features reduce the retained volume and promote scouring which will minimize odor and corrosiveness. This model can handle flows of 850 GPD.

The internal check valve assembly, located in the grinder pump, is

custom designed for non-clog, trouble-free operation.

The grinder pump is automatically activated. It runs infrequently for very short periods. The annual energy consumption is typically that of a 40 watt light bulb.

Operational Information

Motor

1 HP, 1,725 RPM, high torque, capacitor start, thermally protected, 120/240 V / 60 Hz, one phase

Inlet Connections

4-inch inlet grommet standard for DWV pipe. Other inlet configurations available from the factory.

Discharge Connections

Pump discharge terminates in 1-1/4" female NPT. Can easily be adapted to 1-1/4" PVC pipe or any other material required by local codes.

*Discharge**

15 gpm at 0 psig

11 gpm at 40 psig

9 gpm at 60 psig

Overload Capacity

The maximum pressure that the pump can generate is limited by the motor characteristics. The motor generates a pressure well below the rating of the piping and appurtenances. The automatic reset feature does not require manual operation following overload.

Patent Numbers: 5,439,180
Patents Pending

* Discharge data includes loss through check valve, which is minimal.

PA2111P01 Rev. - 5/06

1012s

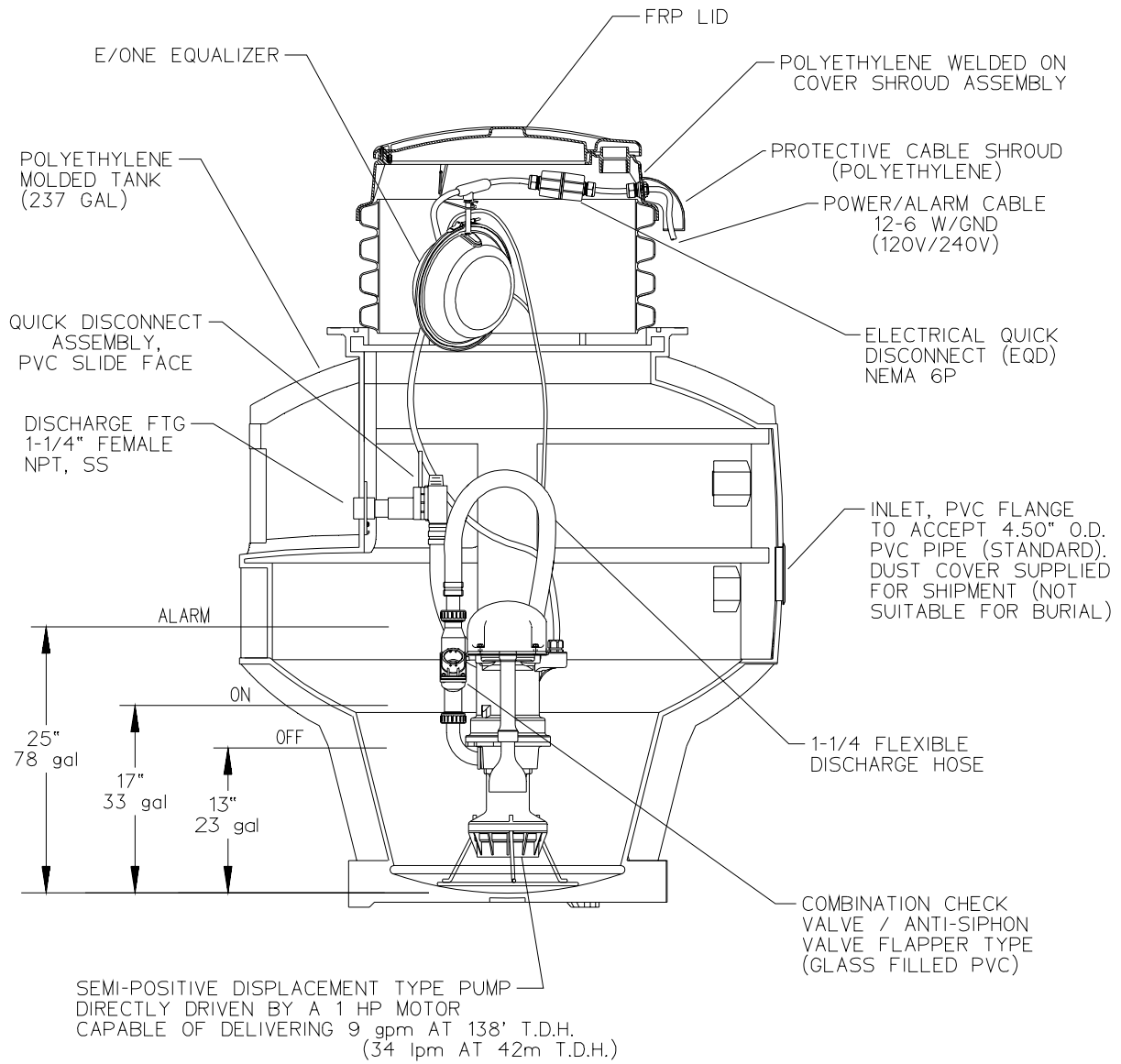

NOTE:
 1012s-55 WITH A FLAT FIBERGASS LID IS ALSO AVAILABLE

BALLAST REQUIREMENTS

A CONCRETE ANCHOR IS REQUIRED ON ALL 1012s STATIONS

SPECIFIC CONCRETE DIMENSIONS ARE REQUIRED TO ACHIEVE NECESSARY BALLAST EFFECT

SEE INSTALLATION INSTRUCTIONS FOR FURTHER DETAILS

AD	CAH	05/02/06	-	1/16
DR BY	CHK'D	DATE	ISSUE	SCALE



DETAIL SHEET 1012s

PA2109P01

1012s -55

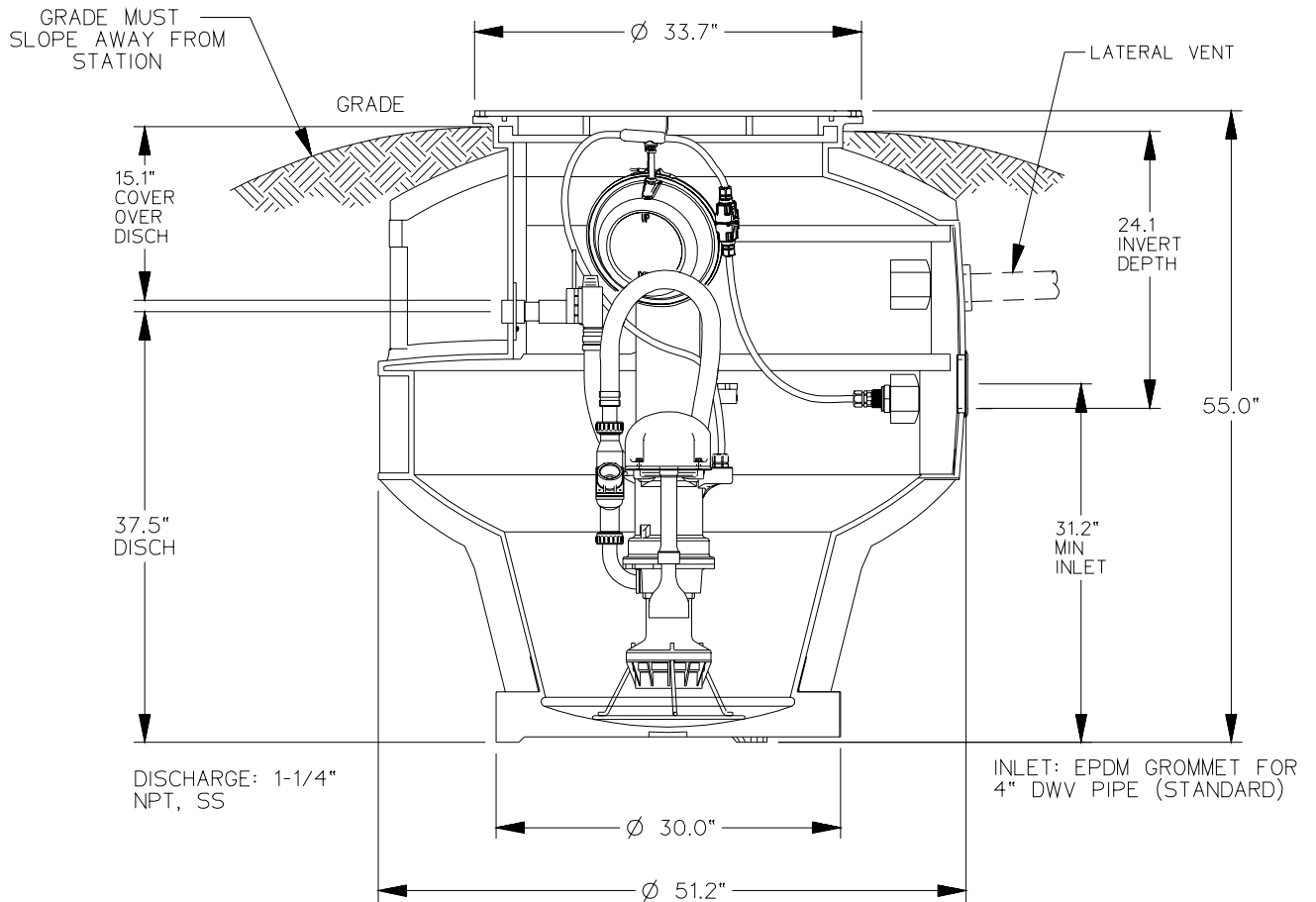

NOTE:

1. LATERAL VENT GROMMET INCLUDED, VENT PIPE BY OTHERS
2. ALSO AVAILABLE WITH MUSHROOM VENT IN LID

BALLAST REQUIREMENTS

A CONCRETE ANCHOR IS REQUIRED ON ALL 1012s-55 STATIONS

SPECIFIC CONCRETE DIMENSIONS ARE REQUIRED TO ACHIEVE NECESSARY BALLAST EFFECT

SEE INSTALLATION INSTRUCTIONS FOR FURTHER DETAILS

AD	CAH	05/24/06	A	1/16
DR BY	CHK'D	DATE	ISSUE	SCALE
				
MODEL 1012s-55				
PA2110P01				

1012s-73

GRADE MUST SLOPE AWAY FROM STATION

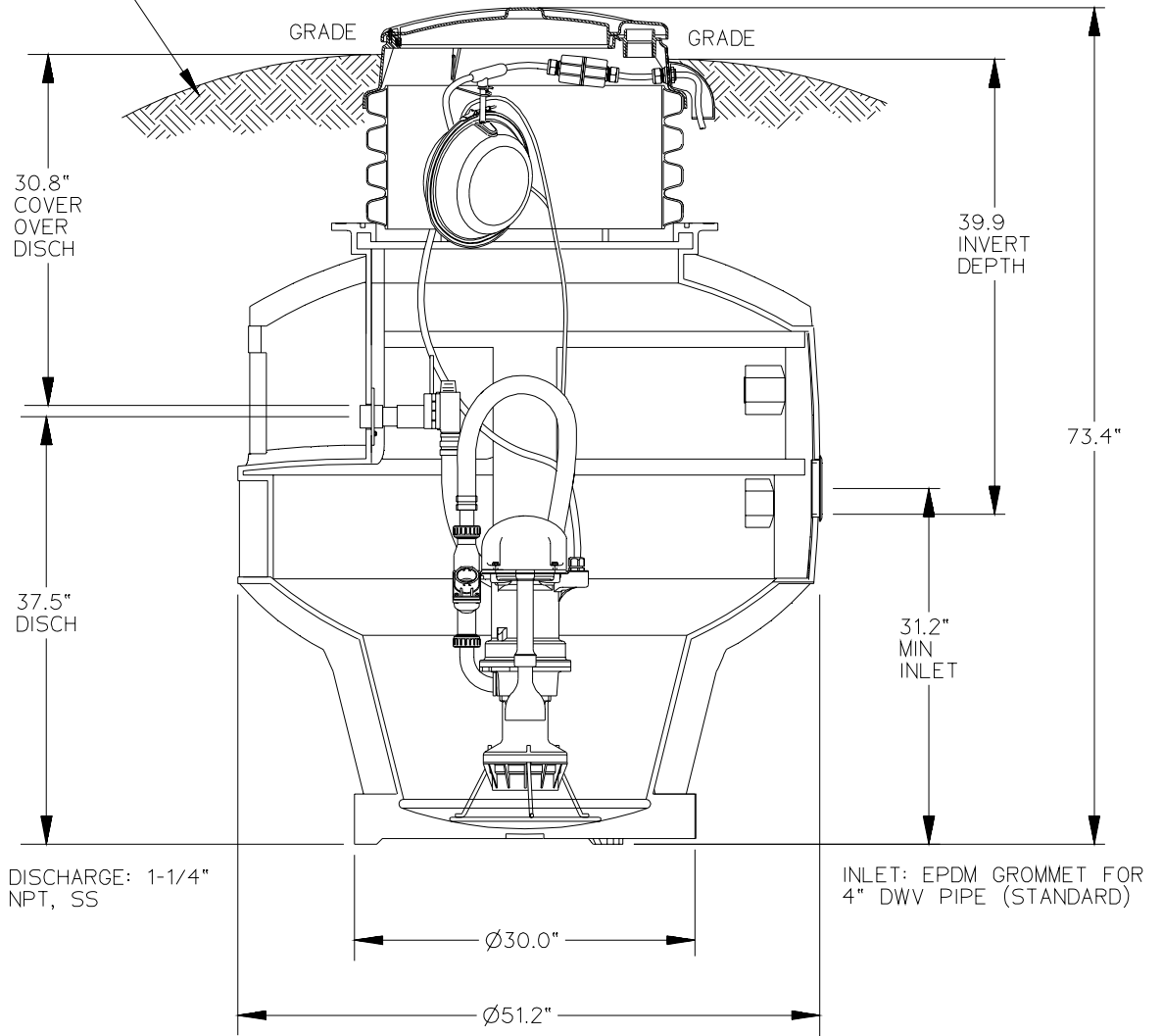

BALLAST REQUIREMENTS

A CONCRETE ANCHOR IS REQUIRED ON ALL 1012s-73 STATIONS

SPECIFIC CONCRETE DIMENSIONS ARE REQUIRED TO ACHIEVE NECESSARY BALLAST EFFECT

SEE INSTALLATION INSTRUCTIONS FOR FURTHER DETAILS

AD	CAH	05/25/06	A	1/16
DR BY	CHK'D	DATE	ISSUE	SCALE



MODEL 1012s-73

PA2107P01

1012s -92

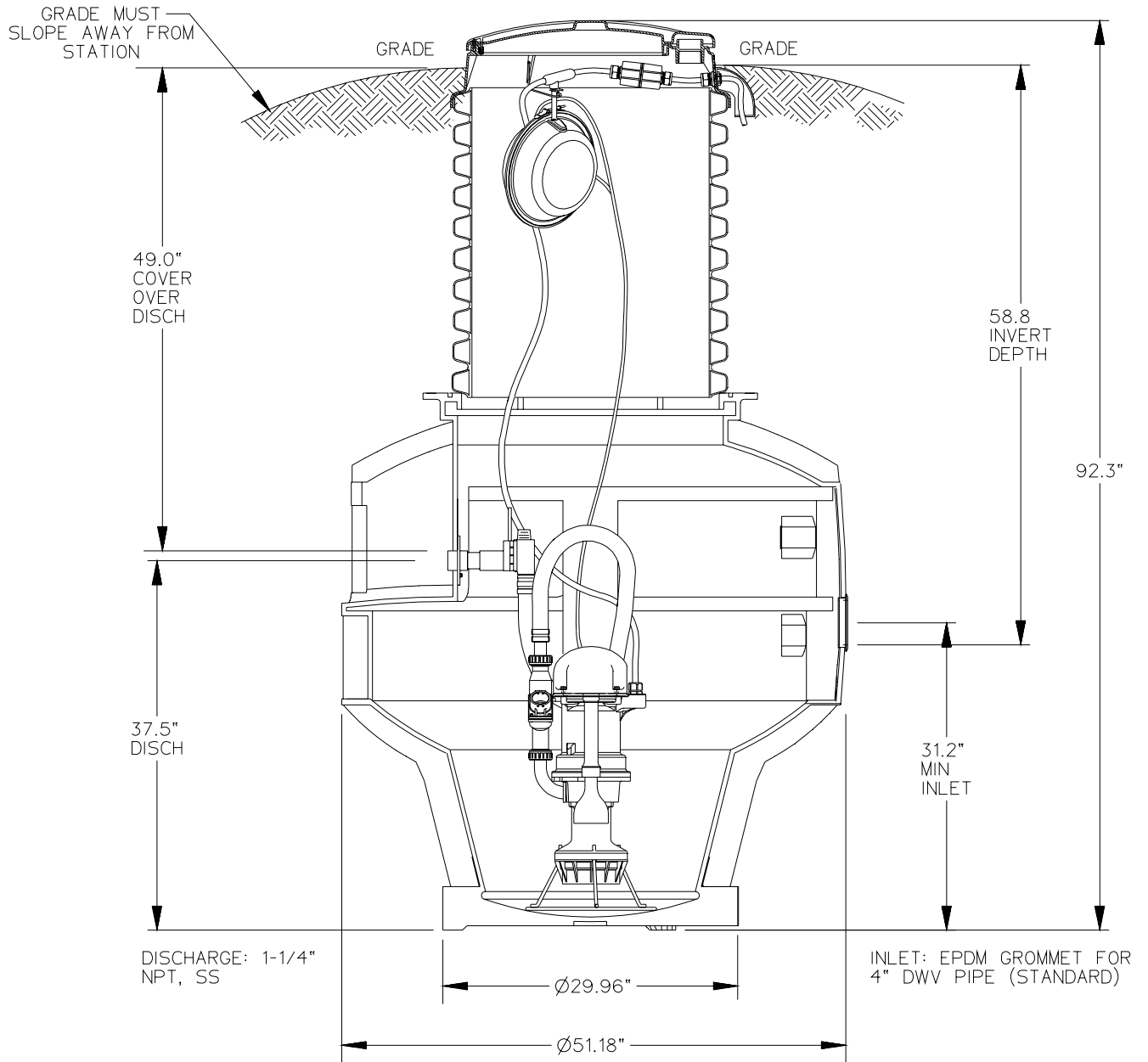

BALLAST REQUIREMENTS

A CONCRETE ANCHOR IS REQUIRED ON ALL 1012s-92 STATIONS

SPECIFIC CONCRETE DIMENSIONS ARE REQUIRED TO ACHIEVE NECESSARY BALLAST EFFECT

SEE INSTALLATION INSTRUCTIONS FOR FURTHER DETAILS

AD	CAH	05/25/06	A	1/16
DR BY	CHK'D	DATE	ISSUE	SCALE



MODEL 1012s-92

PA2108P01