

AMGP

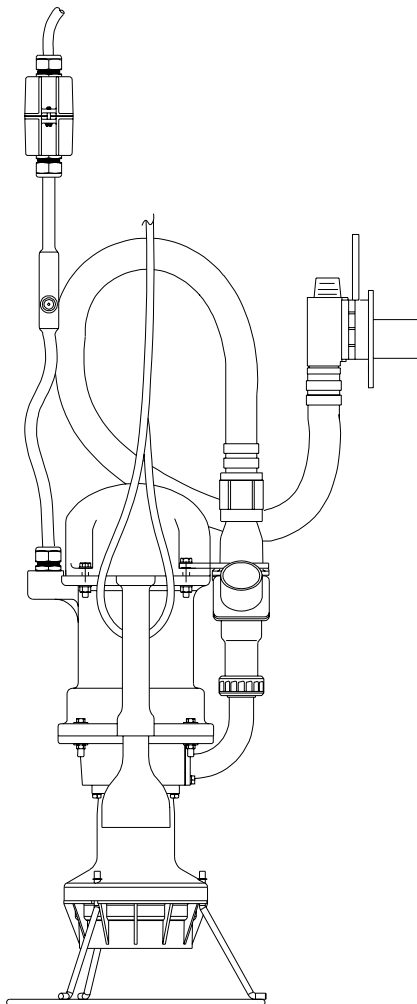

General Applications

The Environment One After Market Grinder Pump (AMGP) is engineered to fit into virtually any grinder pump wet well. Universal design allows easy drop-in conversion, ready to connect. The AMGP is a complete replacement for all of the troublesome components of a centrifugal, including the old unit's slide rails, pump/motor, float switches, piping and motor control devices.

General Features

All solids are ground into fine particles, allowing them to pass easily through the pump, check valve and small-diameter pipelines. Even objects not normally found in sewage, such as plastic, rubber, fiber, wood, etc., are ground into fine particles.

The grinder is designed not to jam and for minimum wear to the grinding mechanism.

The AMGP comes complete with a self-contained level control system, eliminating troublesome float switches. The grinder pump is automatically activated and runs infrequently for very short periods. The annual energy consumption is typically that of a 40-watt light bulb.

The 1 1/4-inch slide face discharge connection is adaptable to any existing discharge piping.

The internal check valve assembly located on the grinder pump is custom-designed for non-clog, trouble-free operation.

Units are available with a number of discharge hose lengths to accommodate a wide range of existing tank depths.

Operational Information

Motor

1 hp, 1,725 rpm, high torque, capacitor start, thermally protected, 120/240V, 60 Hz, 1 phase

Discharge Connections

Pump discharge terminates in 1 1/4-inch female solvent weld fitting; threaded adapter is supplied and discharge can easily be adapted to 1 1/4-inch MPT.

Discharge

15 gpm at 0 psig (0 TDH)

11 gpm at 40 psig (92 TDH)

9 gpm at 60 psig (138 TDH)

Overload Capacity

The maximum pressure that the pump can generate is limited by the motor characteristics. The motor generates a pressure well below the rating of the piping and appurtenances. The automatic rest feature does not require manual operation following overload.

U.S. Pat. 5,439,180

* Discharge Data includes loss through check valve, which is minimal.

LM000100 Rev. D, 12/05

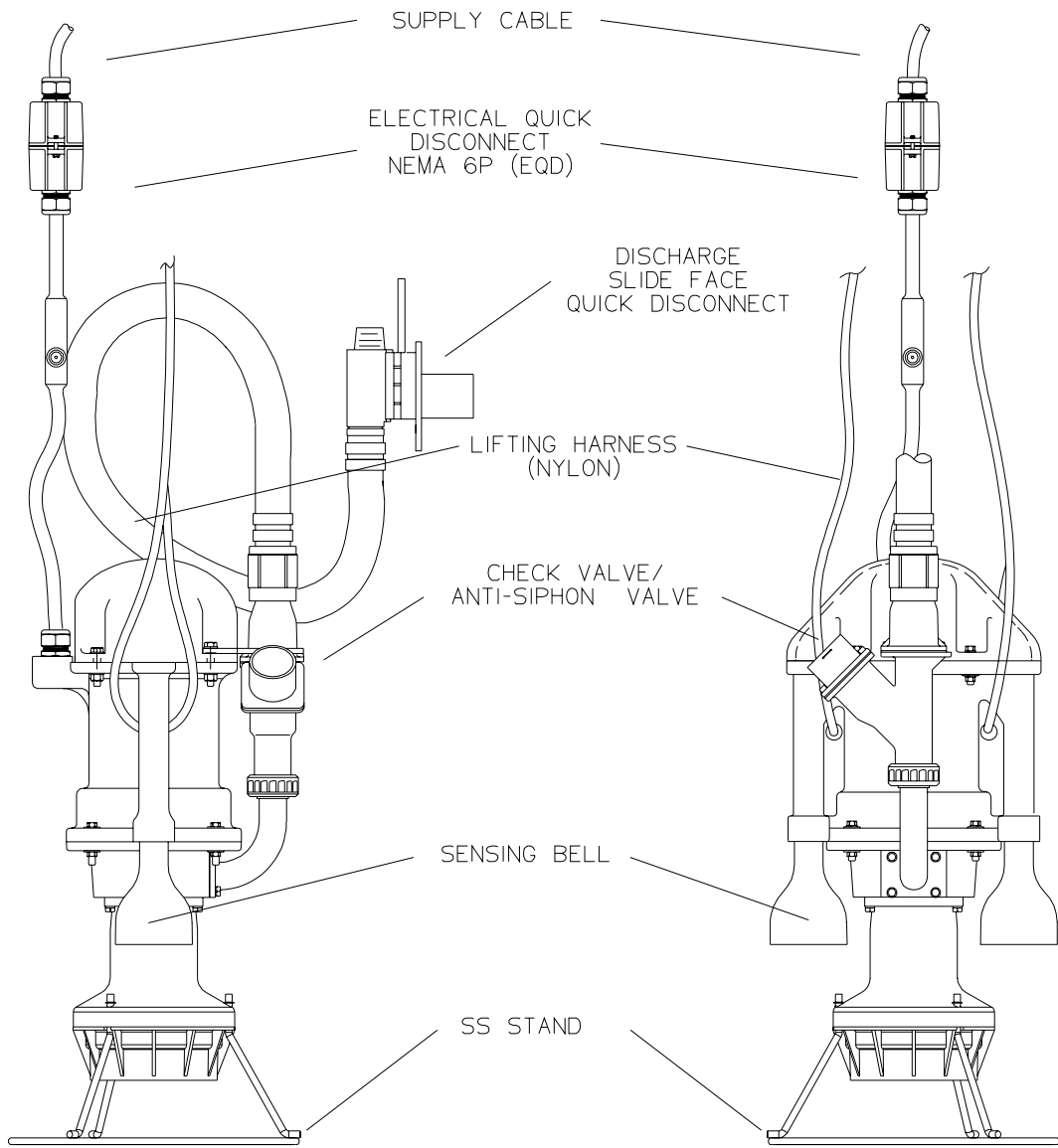

AFTER MARKET
GRINDER PUMP



SGS	CAH	12/22/05	C	1/8
DR BY	CHK'D	DATE	ISSUE	SCALE

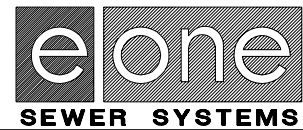

AMGP FEATURES

LM000101

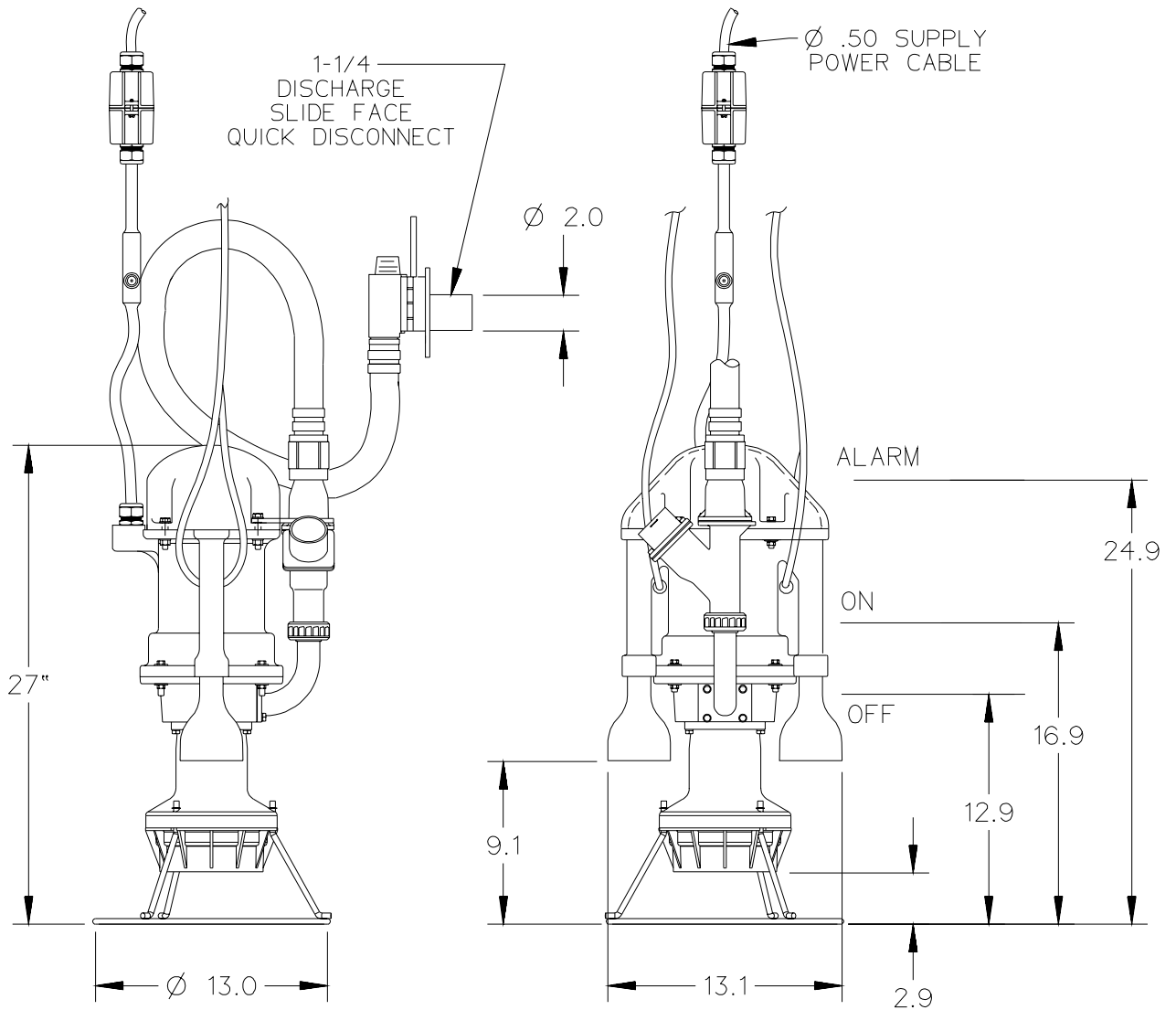

AFTER MARKET
GRINDER PUMP



SGS	CAH	12/21/05	C	1/10
DR BY	CHK'D	DATE	ISSUE	SCALE

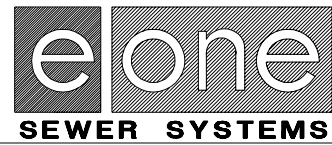

DIMENSION SHEET, AMGP

LM000102

BEFORE

AFTER

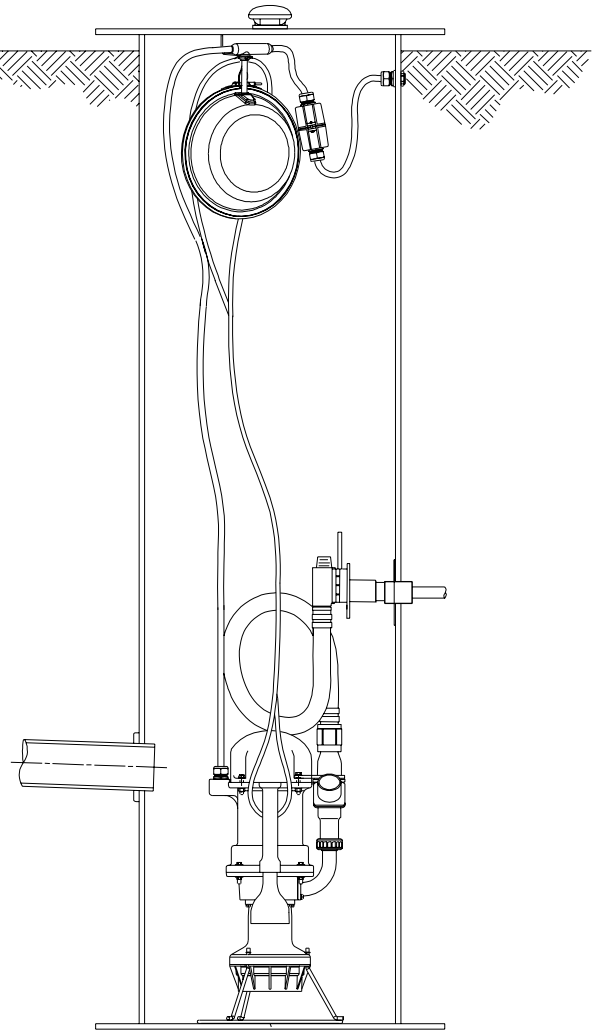
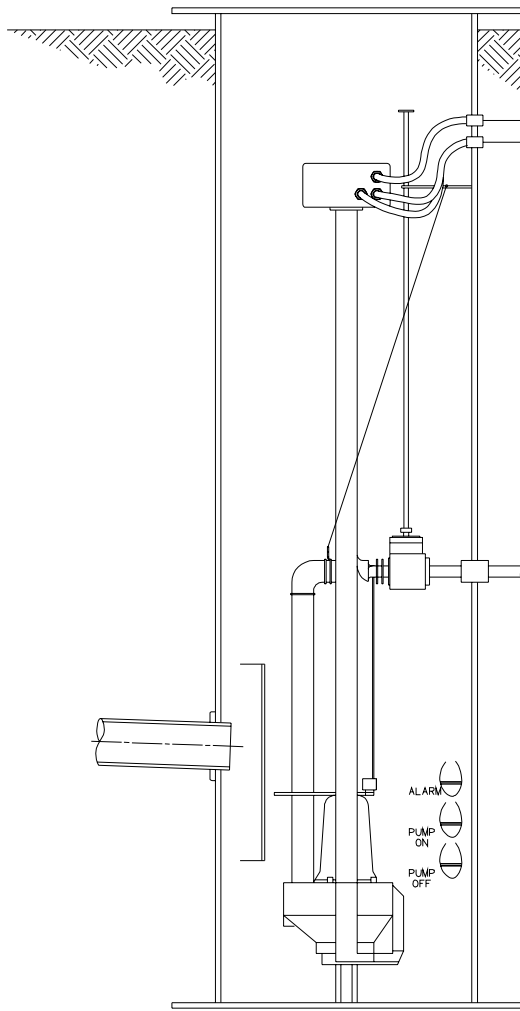

CENTRIFUGAL STATION
TO BE UPGRADED

To...

eone AMGP



DRL	CAH	12-22-05	D	1/16
DR BY	CHK'D	DATE	ISSUE	SCALE

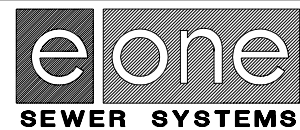

REPLACEMENT ILLUSTRATION

LM000103

* IN THE MAJORITY OF AMGP INSTALLATIONS
THE EXISTING INLET, DISCHARGE, AND
POWER SUPPLY CABLES CAN BE UTILIZED
WITHOUT MODIFICATION INCLUDING J-BOX
AND FEED-THRU'S

TYPICAL SIMPLEX AMGP INSTALLATION

USING VERTICAL SLIDE FACE AND COILED HOSE

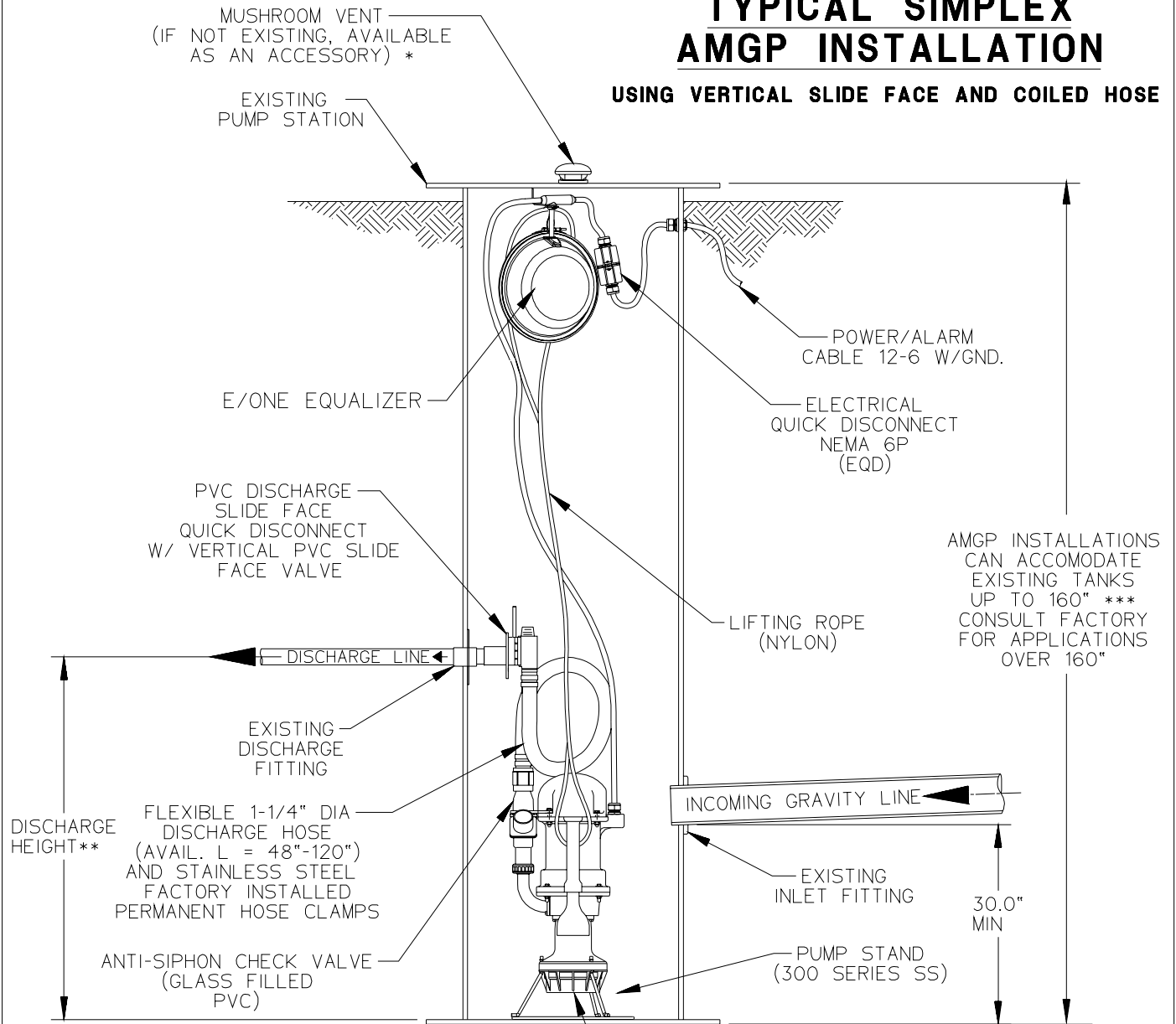

AMGP INSTALLATIONS CAN ACCOMMODATE EXISTING TANKS UP TO 160" *** CONSULT FACTORY FOR APPLICATIONS OVER 160"

DISCHARGE HEIGHT**

SEMI-POSITIVE DISPLACEMENT TYPE PUMP
DIRECTLY DRIVEN BY 1 HP MOTOR
CAPABLE OF DELIVERING 9 gpm AT 138' T.D.H.
(34 lpm AT 42m T.D.H.)

UPC®
ASME A112.3.4



SGS	CAH	12-22-05	E	1/16
DR BY	CHK'D	DATE	ISSUE	SCALE



DETAIL SHEET, AMGP SIMPLEX
VERTICAL SLIDE FACE, COILED HOSE

LM000104

- * STATION MUST BE VENTED
- ** DISCHARGE HEIGHT MUST BE KNOWN WITHIN 3 FEET TO ORDER PROPER KIT
- *** DISCHARGE HEIGHT MUST NOT BE GREATER THAN 150 INCHES

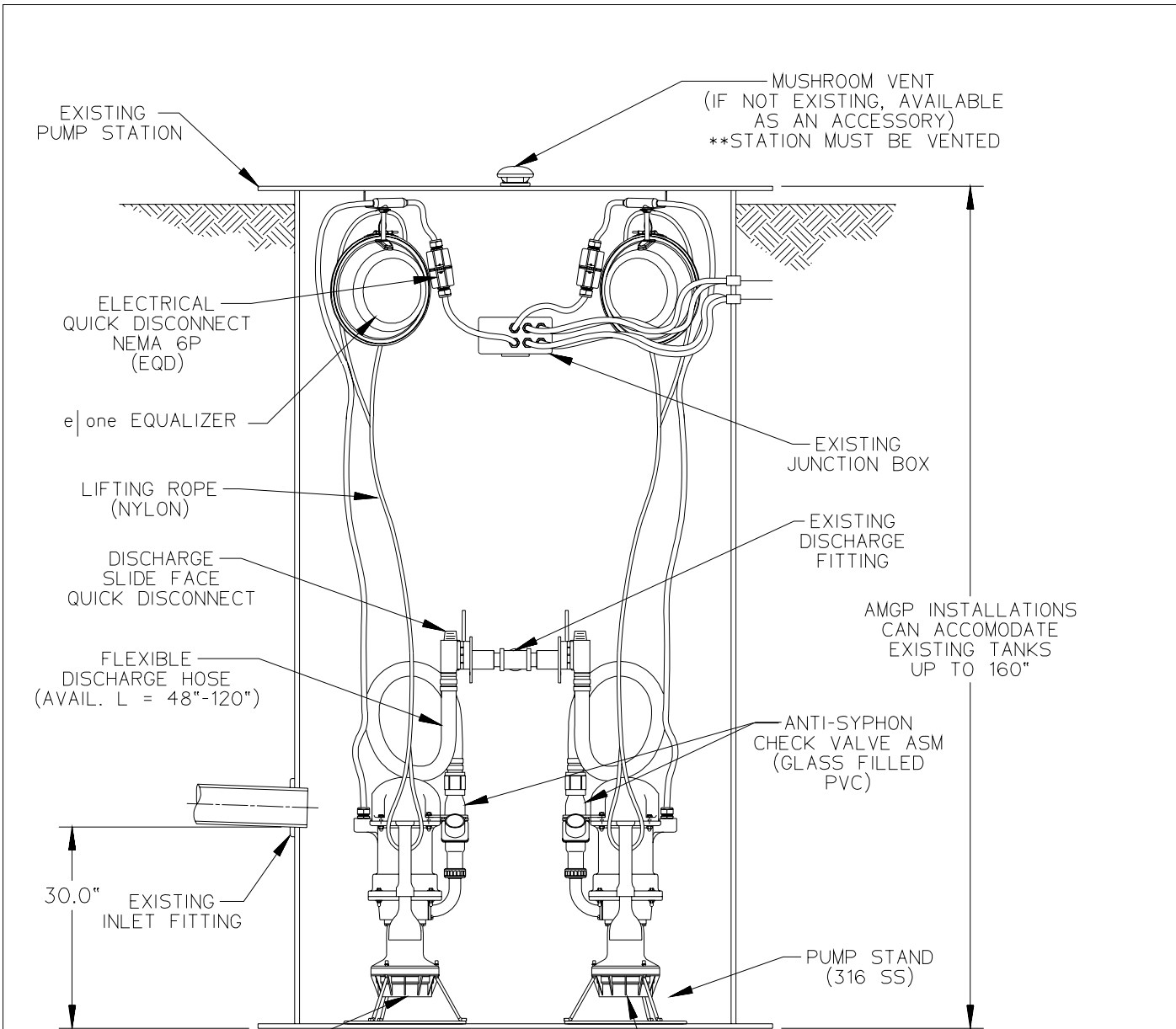

EXISTING PUMP STATION

MUSHROOM VENT
(IF NOT EXISTING, AVAILABLE AS AN ACCESSORY)
**STATION MUST BE VENTED

ELECTRICAL QUICK DISCONNECT NEMA 6P (EQD)

e|one EQUALIZER

LIFTING ROPE (NYLON)

DISCHARGE SLIDE FACE QUICK DISCONNECT

FLEXIBLE DISCHARGE HOSE (AVAIL. L = 48"-120")

EXISTING JUNCTION BOX

EXISTING DISCHARGE FITTING

AMGP INSTALLATIONS CAN ACCOMMODATE EXISTING TANKS UP TO 160"

ANTI-SYPHON CHECK VALVE ASM (GLASS FILLED PVC)

EXISTING INLET FITTING

30.0"

PUMP STAND (316 SS)

SEMI-POSITIVE DISPLACEMENT TYPE PUMP
DIRECTLY DRIVEN BY 1 HP MOTOR
CAPABLE OF DELIVERING 9 gpm AT 138' T.D.H.
(34 lpm AT 42m T.D.H.)



SGS	CAH	12/22/05	D	1/16
DR BY	CHK'D	DATE	ISSUE	SCALE

TYPICAL DUPLEX
AMGP INSTALLATION

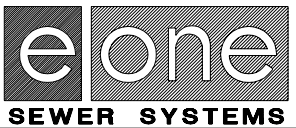

DETAIL SHEET, AMGP DUPLEX
TYPICAL DROP-IN EXISTING STATION

LM000105

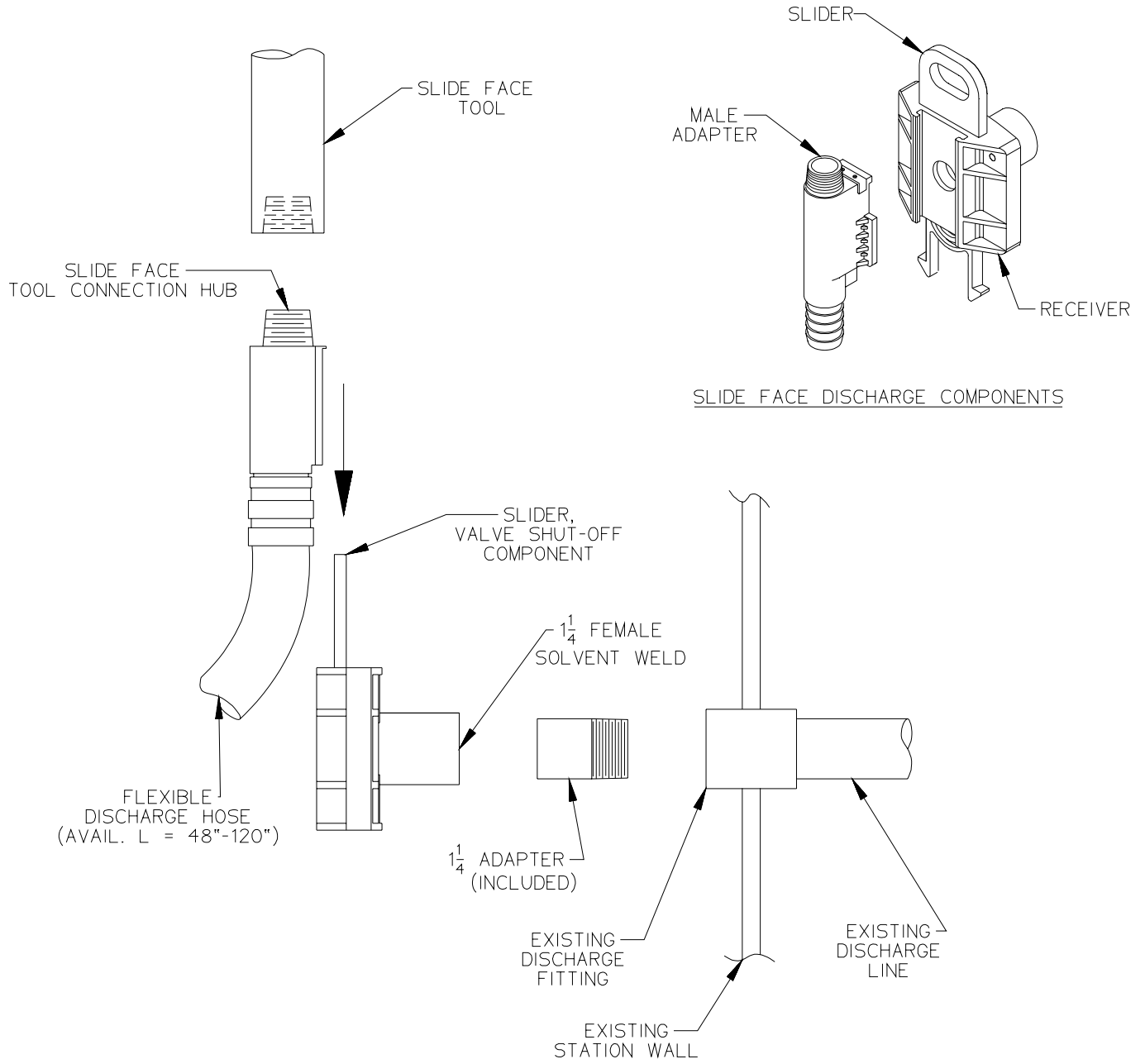

SLIDE FACE DISCHARGE COMPONENTS



SLIDE FACE ASSEMBLY

SGS	CAH	2-04-99	A	1/16
DR BY	CHK'D	DATE	ISSUE	SCALE
				
AMGP DISCHARGE DETAIL				
LM000106				