

# Gatorgrinder

## Typical Installation Instructions





The Gatorgrinder is a well-engineered system designed to provide low pressure sewer service to individual residences or buildings. Proper installation of this equipment will ensure years of trouble-free service.

### PRODUCT DESCRIPTION

The Gatorgrinder station consists of a grinder pump, tank and pump control panel. The tank is a fiberglass basin complete with a gasket-sealed, fiberglass lid. Sewage enters the Gatorgrinder tank through the 4" (standard) inlet pipe where it is ground into fine particles by the grinder pump. The in-line pumping mechanism discharges the ground sewage to a force main, gravity main or a remote treatment site. The pump is a semi-positive displacement type capable of developing discharge pressures up to 60 psig. Ample tank storage capacity in conjunction with integral level sensing controls provides for economic, on-demand, operation of the grinder pump.

### ITEMS REQUIRED FOR INSTALLATION

Prior to beginning installation of the Gatorgrinder station, a thorough review of these installation instructions is recommended. This will likely eliminate problems with inconvenient piping and cable locations or due to unavailable materials or equipment. In addition to the components furnished with each Gatorgrinder station, the following items will be needed to support installation:

- Supply voltage in accordance with the voltage

specified on the Gatorgrinder nameplate.

- Bedding material (Section 2)
- Concrete ballast (Section 3)
- 4" inlet pipe (from residence or building sewer) (Section 5)
- 1-1/4" discharge pipe to force or gravity main (Section 6)
- Compactible backfill material (Section 9)

The following tools:

- 5" diameter hole saw
- 1-1/16" diameter hole saw
- Pipe thread sealant (suitable for PVC)

- Pipe wrenches
- Water pump pliers
- Electric drill, 1/2" chuck
- Common hand tools

### INSTALLATION STEPS

The following instructions will provide the necessary information to properly install the Gatorgrinder system. **All applicable OSHA procedures must be followed during installation of this equipment.**

#### 1. Station Unpacking

(Figure 1)

The Gatorgrinder control panel, grinder pump and tank

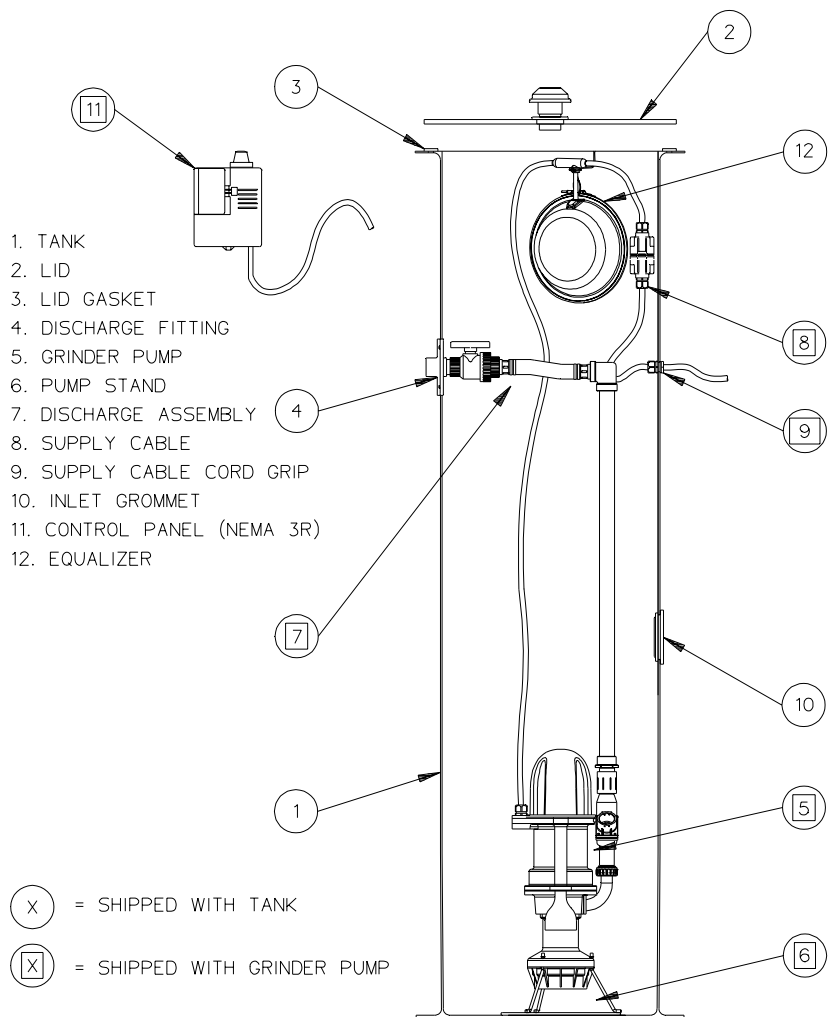

FIGURE 1 - STATION COMPONENTS

are shipped to the job site separately. Inspect the tank (1) and ensure that it sustained no damage during shipment. Proper handling of the fiberglass tank will ensure reliable performance. Do not drop the fiberglass tank or roll it on its side. Only a non-marring sling should be used to lift the fiberglass tank.

Ensure that all lifting equipment is rated for the load being lifted. Verify that the discharge fitting (4) is installed on the tank. Remove the fiberglass tank lid (2) and verify that the lid gasket (3) is installed.

The balance of the factory provided components were delivered with the grinder pump unit. Inspect the shipping cartons for signs of any damage sustained during shipment.

If damage is suspected on any of the Gatorgrinder components, do not proceed

with installation. Notify a Gatorgrinder representative of any damage discovered.

Open the shipping cartons and verify that the grinder pump (5), pump stand (6), discharge piping kit (7), supply cable (8), cable grip (9), inlet grommet (10) and control panel (11) are enclosed. Notify a Gatorgrinder representative about any missing components.

## 2. Site Excavation

Excavate a hole of sufficient depth and width to accommodate the tank, underground piping and required backfill material as well as providing adequate working space for plumbing and electrical connections. The base of the excavated hole should be level and prepared with proper bedding material, such as gravel, in accordance with the site Engineer's requirements. The depth of the

excavation must be sufficient to accommodate the bedding material and tank burial to approximately 1" below the upper flange surface. The size, shape and shoring requirements of the excavation will be based on the soil conditions and should be in accordance with the site Engineer's recommendation and safety requirements.

## 3. Tank Installation

(Figure 2)

Improper handling of the fiberglass tank may result in damage and, ultimately, failure of the station. Care should be taken during lifting and placement to prevent impacting or otherwise damaging the tank. A non-marring sling should be used when lifting the tank by the fiberglass surfaces. Ensure that lifting sling is rated for the load being lifted. Lifting chains or cables should never be

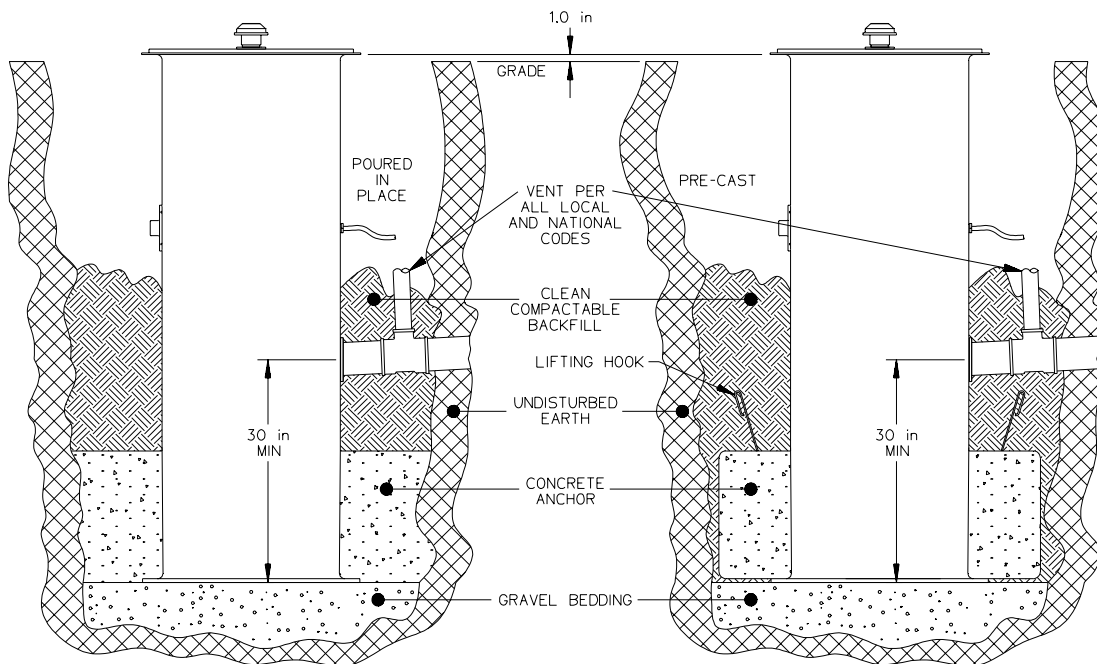

FIGURE 2 - TANK INSTALLATION

placed in direct contact with the fiberglass tank surfaces.

Place the tank on the level bed of fill material in the excavated hole. Orient the installed discharge fitting, as required, to align it with the existing or proposed discharge piping path. Determine and mark the 4" DWV inlet pipe location on the fiberglass tank wall. The inlet pipe location corresponds with the actual or projected point where the 4" building sewer line intersects the tank wall. The center of the inlet pipe must be a minimum of 30 inches from bottom of the tank. The slope of the inlet pipe (per national and local code requirements) must be accounted for when determining the inlet location.

The supply cable path and cord grip location should be considered when selecting the inlet location (Section 8 and Figure 4). If the site conditions require concrete tank ballast to

prevent flotation, ensure that the volume of concrete used complies with the site Engineer's recommendation. Concrete ballast, if required, should be cast in place around the tank in the excavation. **Do not pour the concrete ballast above the marked inlet pipe location.** If the ballast must be poured above this level, proceed with installation of the inlet piping (Section 5) before pouring the concrete. The inlet pipe must be sleeved with an 8" tube prior to pouring. The tank should be filled with water, to a level above the specified ballast height to prevent shifting during the concrete pour.

Alternatively, precast concrete, around the tank bottom, may be used for ballast (Figure 2). Do not pour ballast above the intended inlet location. If this ballast method is used, lifting hooks must be anchored in the

concrete to support subsequent handling of the tank. The lifting hooks must be adequate to support the combined weight of the tank and concrete ballast, and should be sized and installed in accordance with the site Engineer's recommendation.

Place the ballasted tank in the excavated hole using the lifting hooks. **Do not lift the tank by any of the fiberglass surfaces if precast ballast is utilized.**

#### 4. Vent Installation

The Gatorgrinder station is supplied with a 2" mushroom vent, to be installed in the station cover.

Locate the 3" hole in the station cover. A vent hole may be added to a station cover in the field using a 3" diameter hole saw. **Consult the factory before installing a vent hole in an existing station cover.**

Install the rubber grommet in the hole in the station. The flange on the grommet should sit flush with the station cover.

Apply soap to the end of the nipple on the vent assembly. Align the nipple on the vent assembly with the grommet in the station cover and press the vent assembly down into the grommet until the vent housing bottoms on the grommet.

#### 5. Inlet Installation

(Figure 3)

The type, size and venting requirements of the inlet pipe must be in accordance with all national and local plumbing codes. The Gatorgrinder is a sewage handling pump and requires ventilation for proper and safe operation.

The Gatorgrinder is supplied

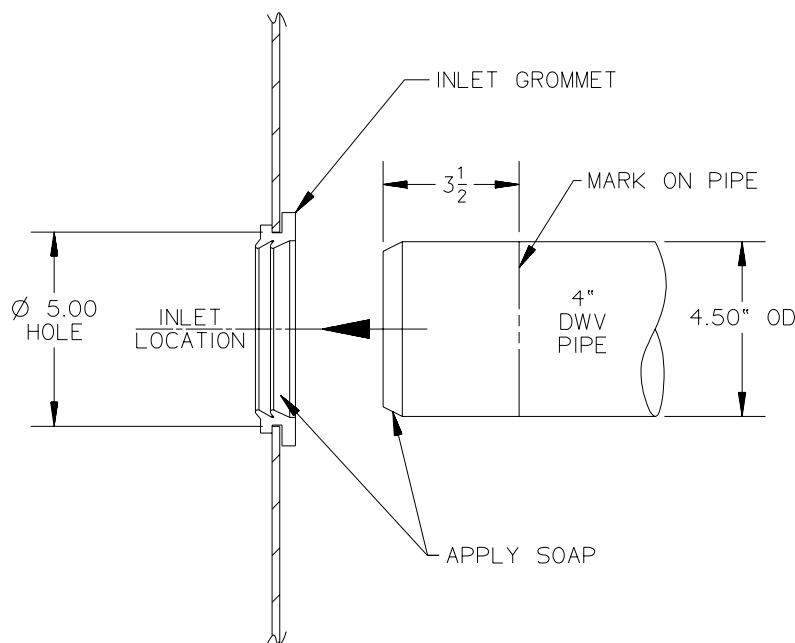

FIGURE 3 - INLET INSTALLATION

with a standard grommet to accept a 4" DWV (4.5" outside diameter) sewer inlet pipe. The grommet is self-sealing and does not require the use of additional sealant or adhesives. Other grommet sizes are available upon request. Verify that the grommet supplied with the Gatorgrinder will accommodate the selected inlet piping.

Using a 5" hole saw, drill through the fiberglass tank wall at the marked inlet location. Install the supplied inlet grommet in the 5" hole.

Place a mark on the inlet pipe 3 1/2" in from the end that will enter the fiberglass tank. A bevel should be ground or filed on the pipe end to aid in installation through the grommet. Clean the grommet and pipe surfaces to remove any debris. Apply a film of pipe soap or dish soap to the outside surface of the inlet pipe end and the inside of the grommet. Insert the pipe end into the grommet and push the inlet pipe into the fiberglass tank until the 3 1/2" mark lines

up with the grommet outside edge.

Inspect the grommet flange on the outside of the tank. The flange should be flush against the tank wall and completely visible when the pipe and grommet are installed properly.

## 6. Tank Discharge Piping Connection

Connect the tank discharge piping to the threaded tank fitting. The 1 1/4" NPT female thread on the discharge fitting will accommodate a variety of pipe materials and fittings. The discharge fitting is made of reinforced Nylon and the threads may be damaged if overtightened. Use a suitable threaded adapter and thread sealant to connect the discharge piping to the tank fitting. Typically, 1/2 to 1 1/2 turns beyond hand tight will produce a leak proof seal.

Discharge piping must be selected in accordance with local and national plumbing codes. If allowable, the use of 1 1/4", Schedule 40, Type 1, PVC pipe or SDR 11

polyethylene pipe is recommended. If polyethylene discharge piping is used, compression type fittings that provide a smooth inner passage should be utilized.

## 7. Control Panel Mounting

Before proceeding, verify that the supply voltage is the same as the motor voltage shown on the grinder pump nameplate. Determine the location of the Gatorgrinder control panel.

The control panel may be mounted on a pole or directly on an outdoor wall surface. The mounting location selected must be visible from the Gatorgrinder station location and provide general visibility to the occupants of the building.

To mount the control panel, remove the panel front cover and secure to the wall or pole using standard #10 or #12 screws through the two mounting holes located on the back panel.

## 8. Supply Cable Installation (Figures 4 & 5)

A 32' supply cable and cord grip are provided with the Gatorgrinder station for electrical connection between the station and the control panel. All electrical wiring must be in accordance with local codes. The supply cable is rated under the National Electric Code (NEC) for direct burial as long as a minimum of 24" of ground cover is maintained. Those portions of the cable with less than 24" of cover must be housed in a suitable protective conduit.

The supply cable terminates in a convenient, electrical

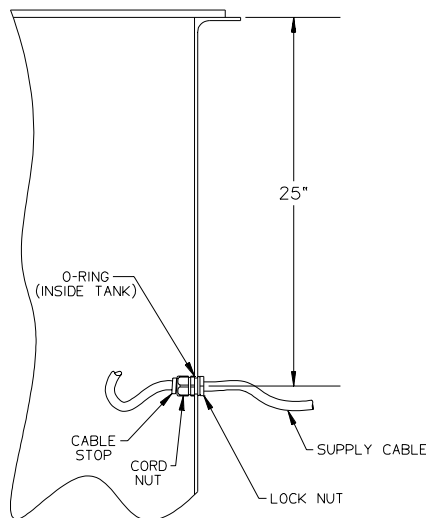

FIGURE 4 - SUPPLY CABLE INSTALLATION

quick-disconnect (EQD) plug to support future servicing of the grinder pump. The supply cable cord grip provides a leak tight seal around the power cable as it enters the tank and will prevent movement of the supply cable during burial and subsequent ground settlement. The cord grip should be installed in a position on the tank that will provide convenient, direct routing of the supply cable to the control panel. The supply cable cord grip should be installed 25" below the top of the tank (see Fig. 4).

Exception: On 48" tall tanks the cord grip should penetrate the tank 18" below the top of the tank; the portion of the cable with less than 24" of soil cover shall be installed in suitable protective conduit.

Locate and mark the location of the cord grip on the fiberglass tank wall. Using a 1 1/16" hole saw, drill through the tank wall at this location. Install the cord grip and O-ring seal as shown. Tighten the cord grip locknut until snug.

Loosen the cord nut and slide the supply cable free end through the cord grip (Figure 4). Continue to slide the entire cable length through the cord grip until the metal cable stop rests against the cord grip face. Tighten the cord nut until snug. Failure to tighten the cord nut will result in groundwater entering the station.

Use care when installing and burying the supply cable. If the cable is cut or otherwise damaged it may result in a pump malfunction. Run the supply cable underground, ensuring 24", minimum, of soil

coverage, to the control panel location. Leave a 6" to 12" loop of supply cable near the station and the control panel to accommodate settlement of the soil. A protective conduit must be utilized where 24" of soil cover cannot be maintained (Figure 5).

### 9. Tank Backfill

Proper backfill is essential to the long-term reliability of the Gatorgrinder station. The choice of backfill material is dependent upon the local soil and groundwater conditions and must be in accordance

with the site Engineer's recommendation. Heavy, non-compactible clays and silts are not acceptable backfill for the Gatorgrinder tank or any other underground structure such as the inlet or discharge piping.

Backfill should be placed and compacted in 12" lifts. Special care should be taken when placing backfill around inlet and discharge piping to ensure support and compaction. Do not strike the inlet pipe, discharge pipe or electrical connection with the compaction equipment during backfill.

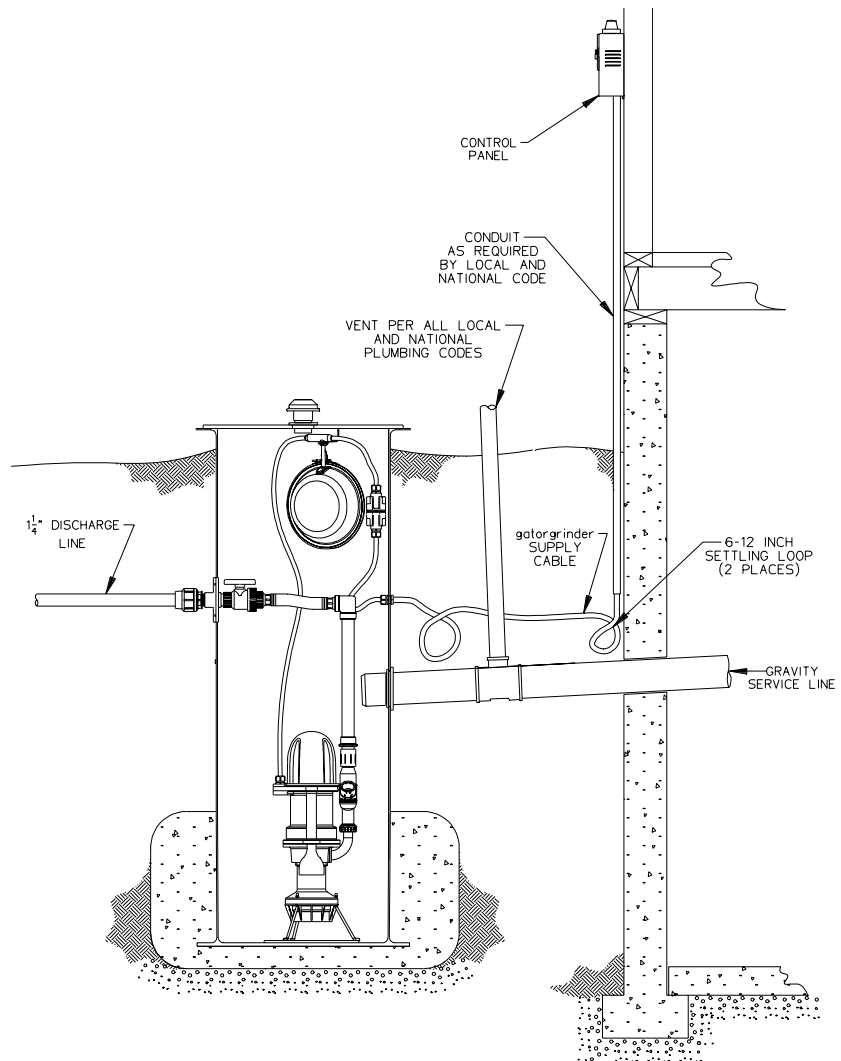

FIGURE 5 - TYPICAL STATION INSTALLATION

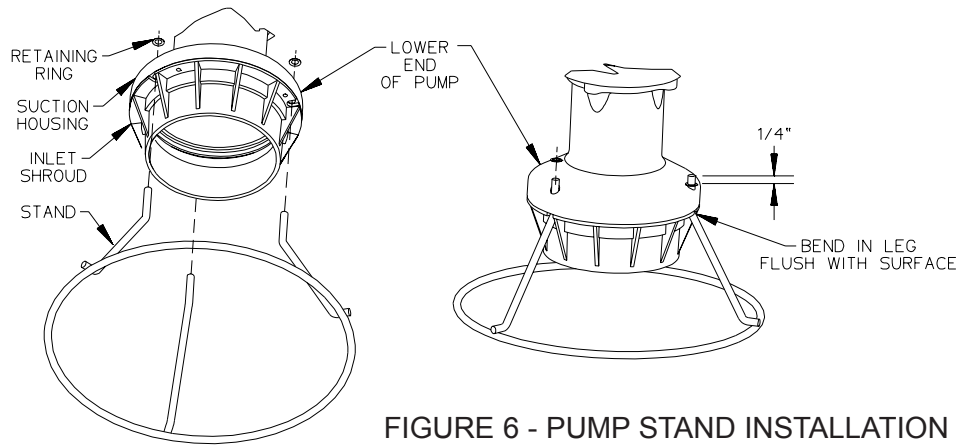

FIGURE 6 - PUMP STAND INSTALLATION

The finished grade should be 1" below the upper flange on the fiberglass tank. The finished grade should be sloped down from the station to prevent water from pooling around the tank.

**10. Grinder Pump Stand Assembly**

(Figure 6)

Detach the three stand retaining rings from the pump stand. Temporarily rest the grinder pump on its side. Using a block of wood or similar object, prop up the lower pump end to allow installation of the pump stand. Align the three legs of the pump stand with the three holes in the pump lower end. Push the stand legs into the pump lower end until the bend in each stand leg bottoms against the pump-housing surface.

Turn the pump upright on the installed stand. Install one stand retaining ring on each of the three leg ends protruding through the pump lower end. The retaining rings are a pressure fit and are easily tapped in place using a 5/16" socket or nut driver and mallet. The retaining rings should only

be driven onto each leg approximately 1/4". Do not attempt to bottom the rings against the angled pump surface as this may distort the ring and lessen its holding power.

**11. Grinder Pump Installation**

Prior to installing the grinder pump in the tank, flush the inlet pipe with water to force any miscellaneous debris in the sewer line into the tank. Heavy debris such as sand, clay, etc. should be removed from the tank before installing

the grinder pump.

The Gatorgrinder was supplied with all of the necessary plumbing components to connect the pump discharge to the tank discharge.

Refer to the separate Gatorgrinder Discharge Plumbing Installation Instructions for the specific discharge arrangement included with this unit.

After completing the plumbing connections per the Gatorgrinder Discharge

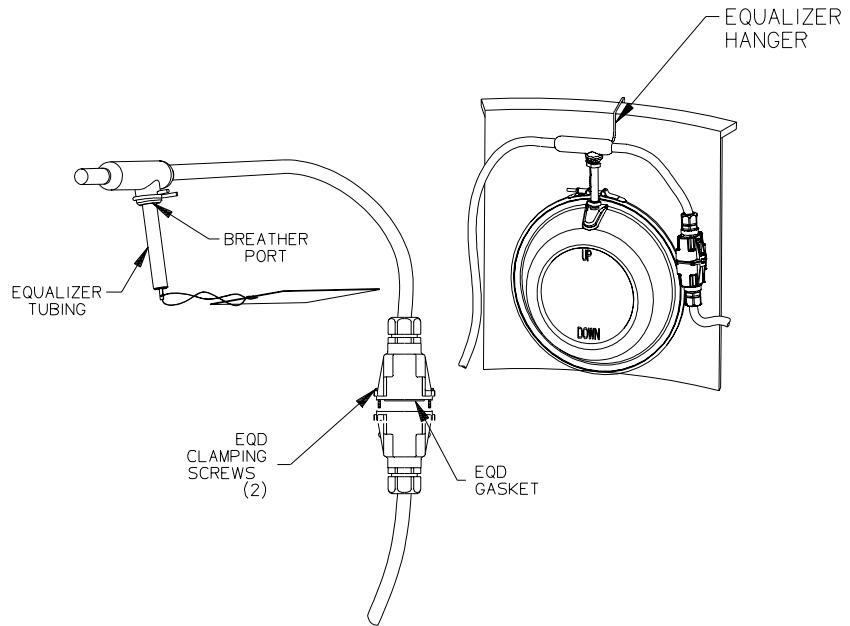

FIGURE 7 - PUMP PLUG CONNECTION

Plumbing Installation Instructions Discharge, proceed with connecting the pump power cable.

The grinder pump power cable is supplied with the mating half of the EQD connector. Verify that the EQD gasket is in place on the grinder pump power cord (Figure 7). Plug the pump power cable into the supply cable EQD connector. Note that the EQD halves are “keyed” and the plug connections can only be made one way. Secure the EQD connection by tightening the two clamping screws until the EQD plastic “stops” are in contact with each other. Remove the plug from the equalizer tube installed in the breather port and insert barbed fitting on the equalizer (Figure 7). Hang the equalizer hanger over the tank flange.

### 12. Electrical Connections

The Gatorgrinder control panel contains a circuit breaker

pair to protect the pump motor and a separate circuit breaker to control the alarm circuit. The station supply cable and power supply cable (from the building service) must be run into the panel and appropriately connected. All panel wiring should be completed by a qualified electrician and be in compliance with national and local electrical codes. Conduit should be provided, where required by code, and adequate strain relief used on cable and/or conduit entry points. The appropriate wiring connections for the Gatorgrinder are shown in Figure 8.

### 13. Start-Up Test Procedure

When the system is completely installed, the station should be checked to ensure proper installation and reliable performance.

inspections:

- Proper burial depth — the tank should have been buried to a level 1" below the fiberglass cover flange.
- Proper grading — the surrounding soil should be graded down, away from the station.
- Station supply cable — the station supply cable must not be exposed outside of the station. Suitable conduit must be used where proper burial depth (24") cannot be maintained.
- Control panel — ensure that the control panel is properly mounted and free of any damage. Verify that the control panel has been wired properly in accordance with the wiring instructions in this manual.

### ELECTRICAL TESTS

The following electrical tests are **recommended** prior to operating the grinder pump station. These tests require the use of appropriate electrical

### SYSTEM INSPECTION

Perform the following visual

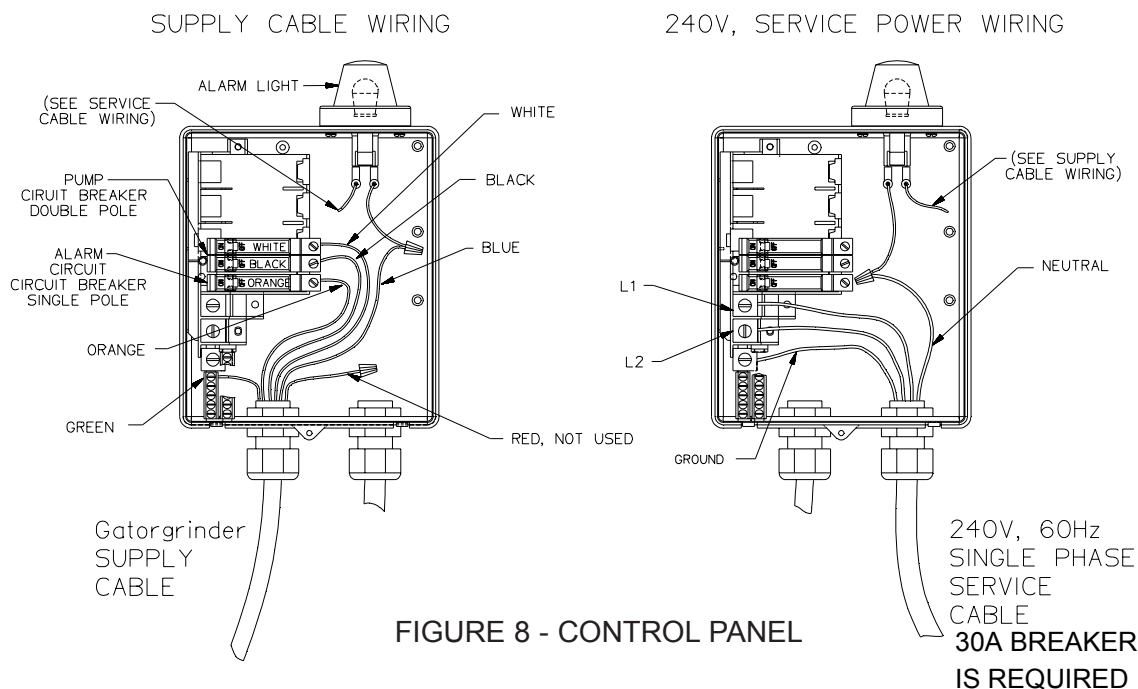

test equipment and should only be performed by qualified personnel trained in the safe operation of this equipment and electrical system servicing.

1. Ensure that the electrical power supplying the control panel is "OFF."

2. Ensure that the grinder pump (double) and alarm (single) circuit breakers in the control panel are in the "OFF" position.

3. Using a test (ohm) meter, set at a 2 meg ohm setting, measure the resistance between the colored wire pairs shown in Table 1. Resistance readings are to be taken in the control panel on the colored leads supplying the pump station (supply cable). Resistance readings other than those shown in Table 1 may indicate a problem with either the supply cable or the grinder pump. **If the measured readings are not as indicated in Table 1, do not proceed with station start-up; contact your local Gatorgrinder or qualified service representative.**

COLOR 1	COLOR 2	NORMAL READING
GREEN	BLACK	:
GREEN	RED	:
GREEN	WHITE	:

TABLE 1

(: = Infinity or open circuit)

4. Turn "ON" the power to the control panel from the building service panel.

5. Using a test (volt) meter, verify that the incoming panel voltage is within 10% of the pump nameplate voltage (for 240V pump, voltage at panel

must be 216V to 264V). **If the voltage is outside of this range, do not continue with station start-up. The voltage problem must be corrected prior to proceeding.**

### START-UP TEST

The following test **must** be performed prior to placing the system in service:

1. Ensure all service and control panel breakers are in the "OFF" position.

2. Open the discharge ball valve at the tank discharge fitting.

3. Open any additional discharge lines. Some installations may have additional discharge line valves before entering the street main.

4. Turn "ON" power to the control panel, from the building service panel.

5. Set the alarm circuit breaker in the control panel to the "ON" position.

6. Fill the fiberglass tank with water until the red alarm light on the control panel is lit.

7. Set the grinder pump circuit breaker in the control panel to the "ON" position. Once power is turned on to the grinder pump:

- The grinder pump should start immediately.
- The red alarm lamp should switch off in approximately one minute.
- The pump should stop within approximately three minutes.

### OPERATIONAL ELECTRICAL TEST

The following electrical test is **recommended** in conjunction

with the Start-Up Test of the grinder pump station. This test requires the use of appropriate electrical test equipment and should only be performed by qualified personnel trained in the safe operation of this equipment and electrical system servicing.

1. The current to the grinder pump should be measured in the control panel, at the white wire supplying the pump station (supply cable).

2. Using an ammeter, measure the current in the white wire while the pump is operating.

3. The current should be between 5 amps and 8 amps.

4. Higher amperage indicates higher discharge pressure.

Measured current in excess of 8 amps could indicate a blocked or closed discharge line. Correct any blockage problems and confirm that the current is within the acceptable range. **If the current remains outside of the acceptable range, and no discharge blockage is detected, contact your local Gatorgrinder or qualified service representative.**

If the grinder pump fails to perform as indicated, review the start-up procedure again and verify that all wiring connections are correct in accordance with these instructions. If the grinder pump still fails to perform as indicated, contact your local Gatorgrinder or qualified service representative.





A Precision Castparts Company

---

Environment One Corporation  
2773 Balltown Road  
Niskayuna, New York 12309-1090

Voice: (01) 518.346.6161  
Fax: 518.346.6188

[www.eone.com](http://www.eone.com)

PA1545P01 Rev. F  
12/11