

## IH091: Home Wastewater Disposal System Installation Instructions & Warranty Information

The Environment One grinder pump is a well-engineered, reliable and proven product. Proper installation ensures years of trouble-free service. The following instructions define the procedure for installing the model IH091 Home Wastewater Disposal System. These instructions cover on-slab and in-slab installations.

This is a sewage handling pump and must be vented in accordance with local plumbing codes.

This pump is not to be installed in locations classified as hazardous in accordance with National Electric Code, ANSI/NFPA 70. All piping and electrical systems must be in compliance with applicable national, state and local codes.

### Required Materials:

- PVC cement
- PVC primer
- Pipe wrench, saw or PVC pipe cutter
- Knife or sheet rock blade
- Pipe dope or teflon tape

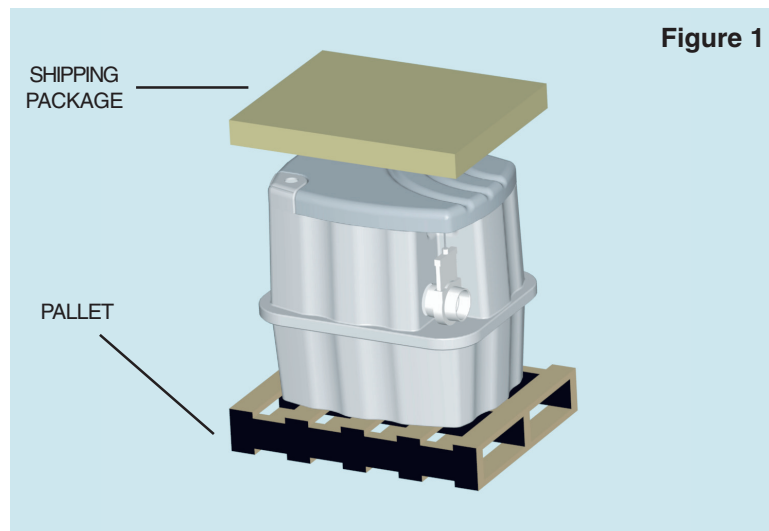

## 1. REMOVE PACKING MATERIAL

The User Instructions must be given to the home owner. Hardware supplied with the unit, if any, will be used at installation.

Do not drop, roll, or lay tank on its side. This will damage the unit and void the warranty.

## 2. TANK INSTALLATION

The tank is supplied with a standard PVC glue joint connecting the 4" DWV (4.50" outside Dia.) incoming sewer drain. The pump may be installed on or in the basement floor. If the tank is to be set on the floor, it must be a flat and level bearing surface.

**If the tank is to go into the basement floor,** it must be anchored to prevent unit from floating due to high ground water. A hole of the correct width and depth should be excavated. The tank must be placed on a 6" bed of gravel made up of naturally rounded aggregate, clean and free flowing, with particle size not less than 1/8" or more than 3/4" in diameter. The tank should be leveled and filled with water prior to pouring the concrete to prevent the tank from shifting. If it is necessary to pour the concrete to a level above the inlet, the inlet must be sleeved with an 8" pipe before pouring. The inlet gate valve should also be protected from the concrete, so it will function correctly. There must be a minimum clearance of three feet directly above the tank to allow for removal of the pump core.

Figure 2

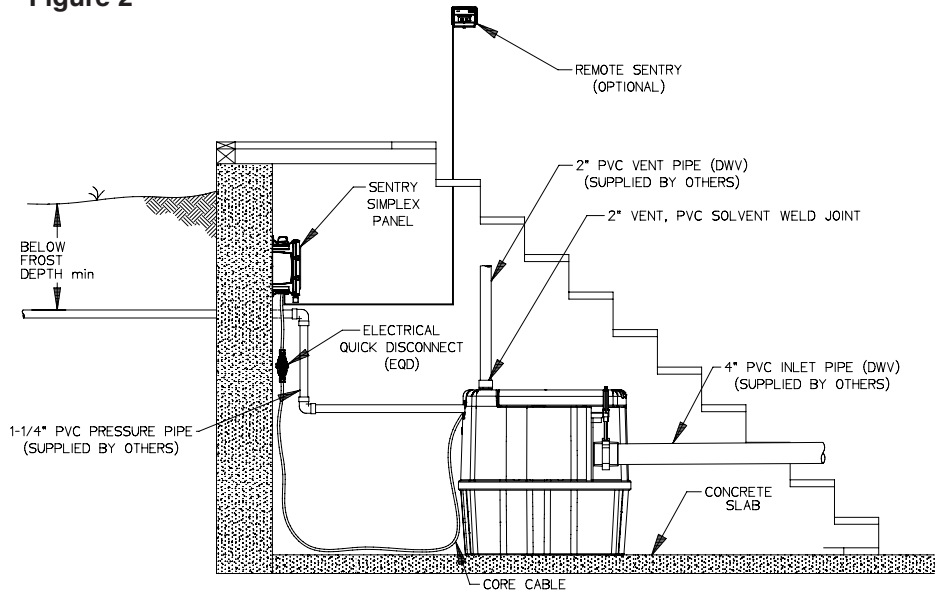
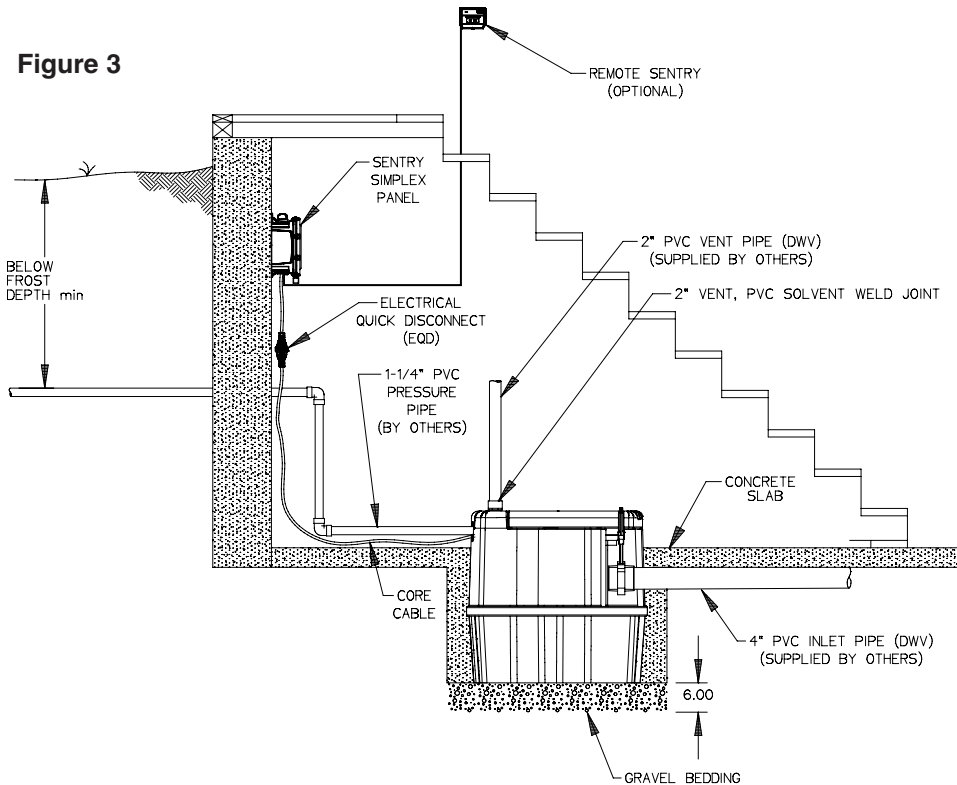

Figure 3



the inlet must be sleeved with an 8" pipe before pouring. The inlet gate valve should also be protected from the concrete, so it will function correctly. There must be a minimum clearance of three feet directly above the tank to allow for removal of the pump core.

### 3. PLACEMENT

Place unit on basement floor, position based on the orientation of the existing sewer/waste pipes. If the unit will be installed in an area where the alarm may not be seen or heard, the Remote Sentry Alarm Module should be installed close to the living area.

### 4. CORE INSTALLATION

Remove the pump from the shipping carton. Locate discharge valve assembly, shipped unattached in a plastic bag. Disassemble the nipple and the valve. Apply pipe sealant to the threads and reassemble the nipple in the union end of the ball valve. Using standard PVC solvent weld practices, install the discharge valve assembly into the PVC elbow on the core. Take care to align the valve handle correctly (Fig. 6). Place the core in the tank, orient the discharge as shown, aligning the slots on the top housing and the threaded holes. Secure the core to the tank, tightening the 1/4-20 x 1-1/4" long bolts to 50 inlb.

### 5. INLET

Remove the station lid. Connect the residence waste line (4" PVC, DWV pipe) to the 4" gate valve on the station. Follow standard practices for PVC solvent welds per all local and national plumbing codes. Make certain that the gate valve is secured in the open (handle up) position.

Figure 4

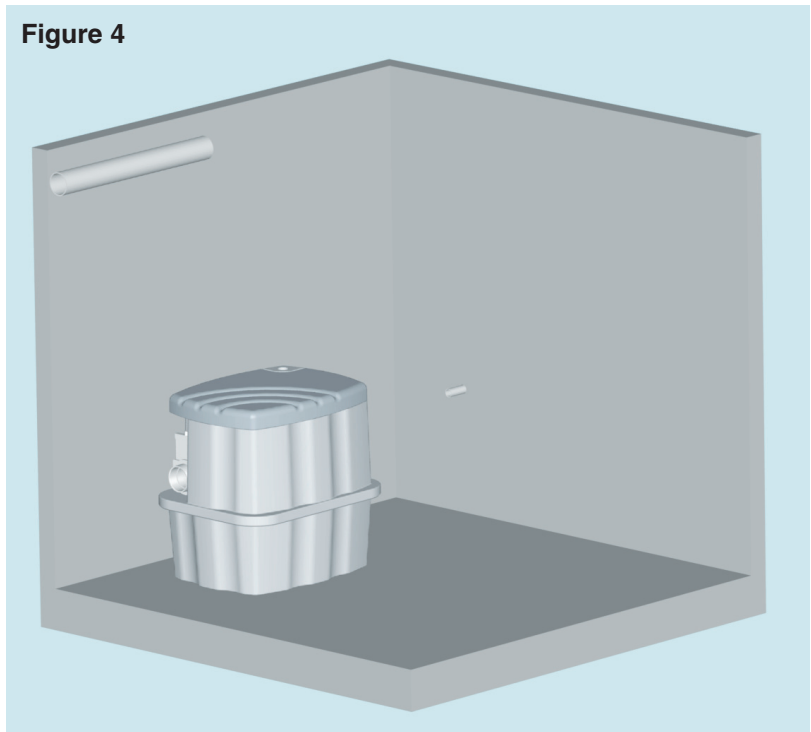

**FAILURE TO COMPLY WITH  
INSTALLATION  
INSTRUCTIONS WILL VOID  
WARRANTY**

Figure 5

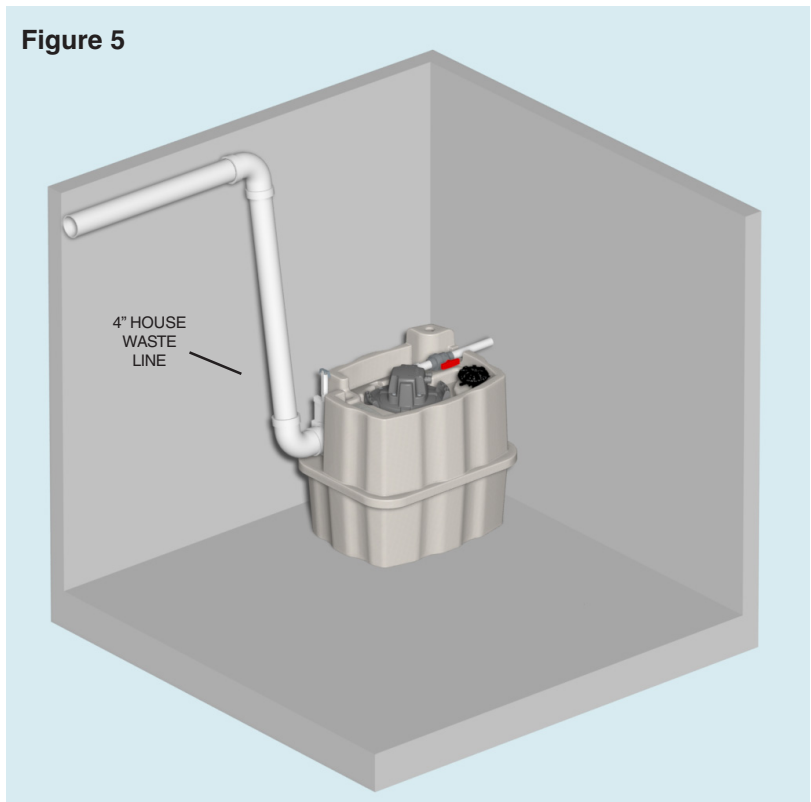

## 6. DISCHARGE

Connect the discharge plumbing; the piping must be 1-1/4" pressure pipe and fittings with a minimum working pressure rating of 200 psi. The use of PVC pressure pipe Schedule 40 is recommended. Ensure the ball valve is in the open (handle horizontal) position.

Redundant Check Valve Assembly (E/One part no. PC0051GXX) should be installed between the pump discharge and the street main on all installations. Never use a ball-type valve as a check valve. E/One recommends the valve be installed as close to the public right-of-way as possible. Check local codes for applicable requirements.

**CAUTION:** *Redundant check valves on station laterals and anti-siphon/check valve assemblies on grinder pump cores should not be used as system isolation valves during line tests.*

## 7. VENTING

The unit must be properly vented to assure correct operation of the pump. Install 2" PVC male adapter fitting (supplied) and 2" PVC vent pipe per all national, state and local codes. Pipe dope or teflon tape must be used on all NPT connections.

***Failure to properly vent the tank will result in faulty operation and will void the warranty.***

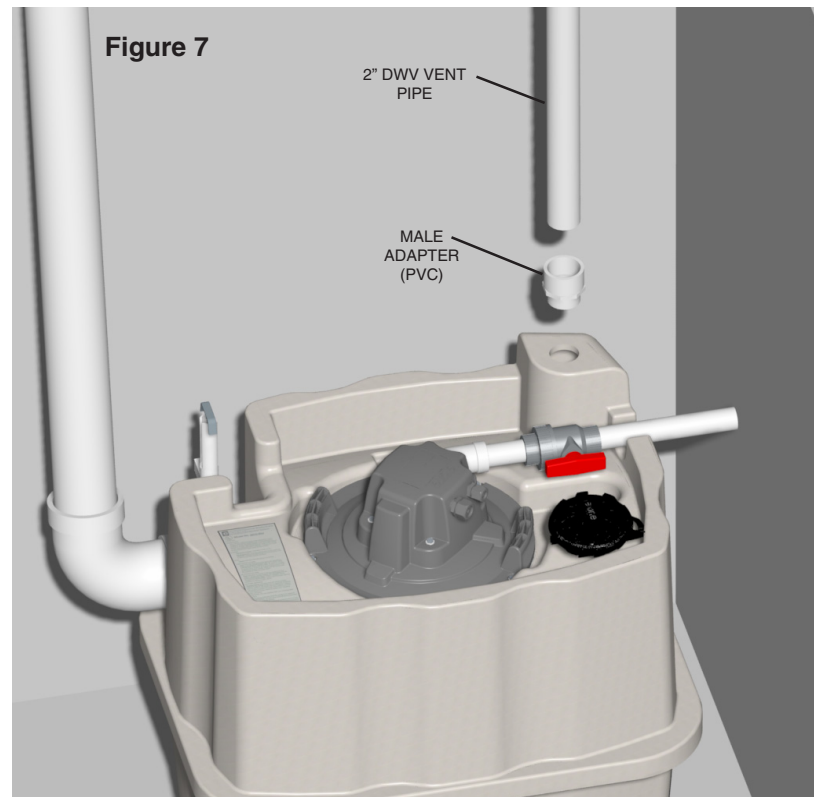
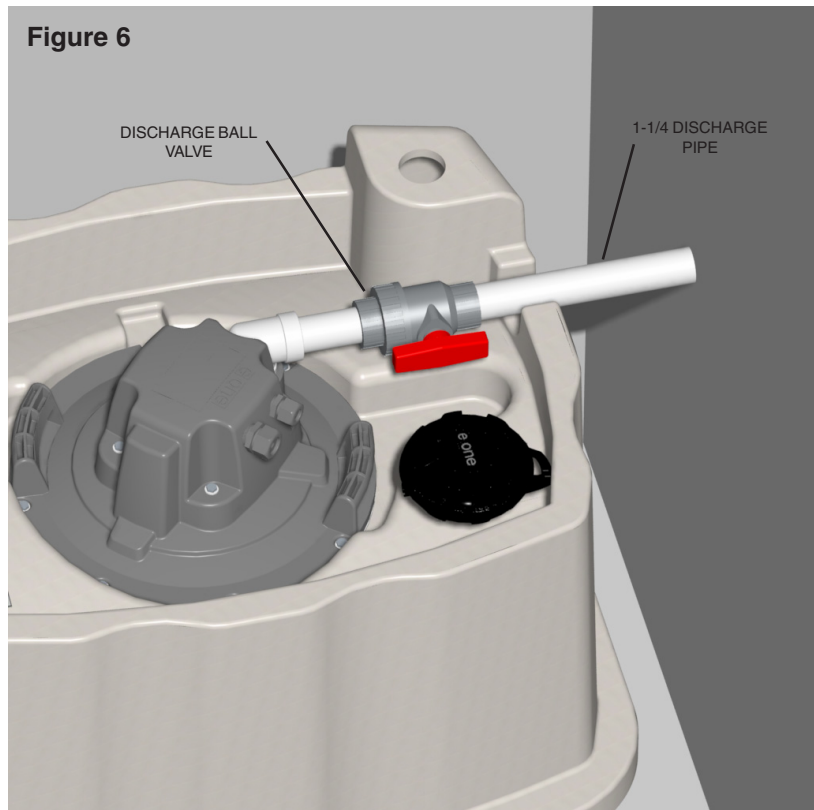

## 8. ELECTRICAL

Before proceeding, verify that the service voltage is the same as the motor voltage shown on the name plate. Install the alarm panel in a conspicuous location where it can be readily seen by the homeowner. An alarm device is required on every installation. There shall be no exceptions.

Mount the E/One Sentry alarm panel on the wall near the station. Connect the alarm panel to a dedicated circuit breaker, 240V, 30A minimum, in the home's breaker box. Use 10-3 with ground cable to supply 240V (L1 & L2), neutral and ground to the alarm panel.

Run the core cable, attached to the pump, along the discharge line and through the notch in the tank, exiting the station. Connect the Electrical Quick Disconnect (EQD) to the EQD end attached to the alarm panel. Ensure the two halves of the EQD are sealed.

## 9. OPTIONAL REMOTE SENTRY

Select a place for the Remote Sentry unit, close to the living area so the alarm can be heard. Mount the unit on the wall using two screws or two nails 3-1/2" apart. The Remote Sentry will be pre-wired to the E/One Sentry alarm panel using 22 gauge wire. Press and hold the Test button; the alarm LED and the buzzer will turn on.

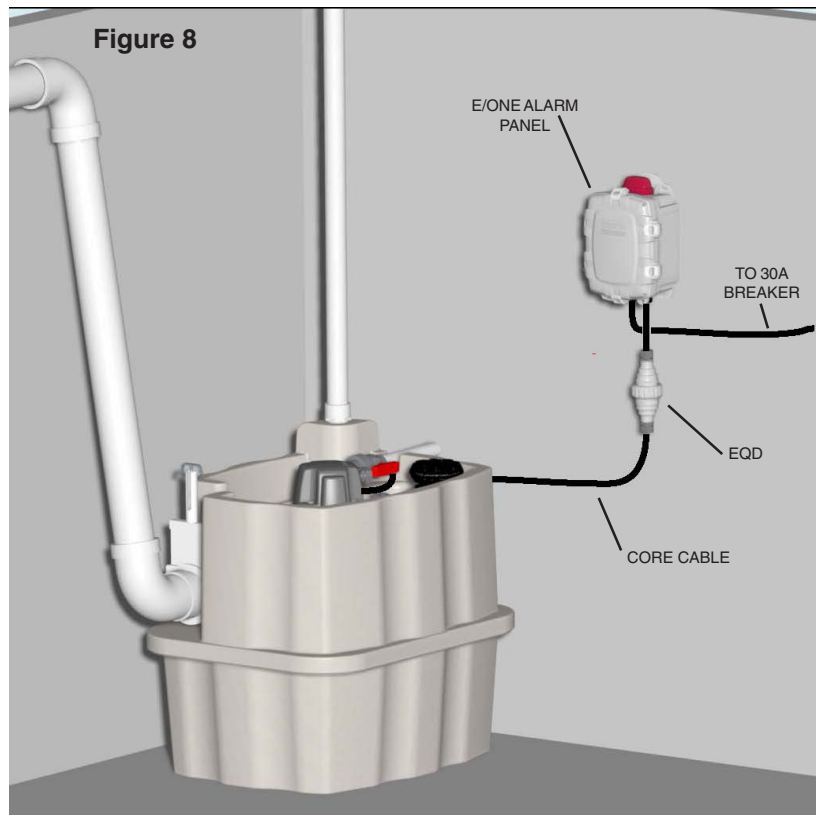
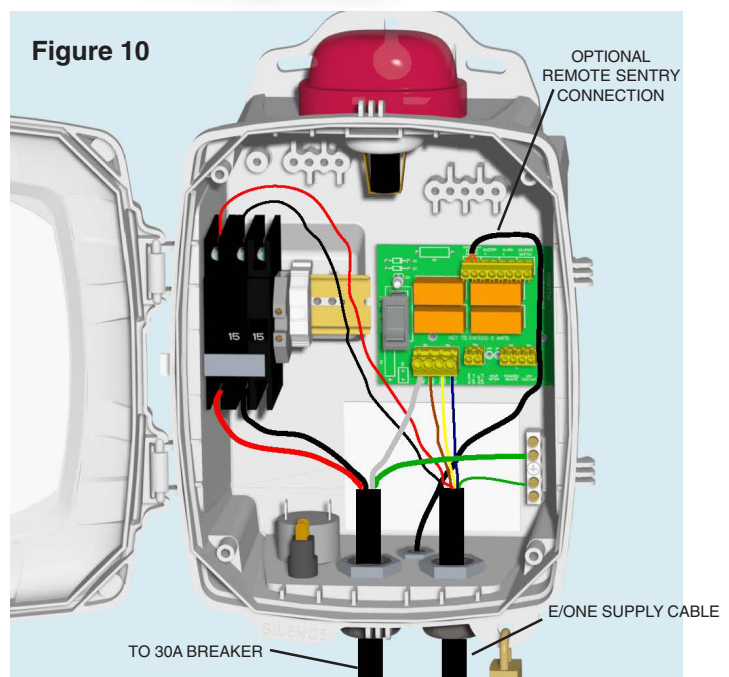

Figure 9



REMOTE SENTRY



## 10. STARTUP PROCEDURE

This procedure must be followed to ensure that the pump and alarm panel function properly. Any problems found during startup must be noted on the startup sheet. This includes problems that are repaired during startup. When a problem is repaired, the date, type of repair and repairperson should be noted.

1. Open the gate valve on the tank inlet (4" gate valve).
2. Open the discharge valve (1-1/4" ball valve).
3. Turn off both circuit breakers in the alarm panel.
4. Fill with water until "High Water Alarm" activates (approximately 70 gallons).
5. Test the voltage at the panel; it should be within 10 percent of the nameplate voltage (240=216 to 264 and 120=108 to 132).
6. Turn on the alarm breaker.
7. Silence the horn.
8. Clip Amp meter onto the black wire (L2) of the supply cable.
9. Turn on the pump breaker.
10. Amperage should be between 5 and 8 amps at 240 volts (10 and 16 amps for 120-volt units). Higher amperage indicates higher pressure. Over 8 amps at 240 volt (or 16 amps at 120 volt) could indicate a plugged or closed line. If you experience a high amperage reading, shut pump off immediately and rectify the problem.
11. Once the alarm turns off, the pump will run for about one minute.
12. After the pump automatically turns off, turn off the power to pump and the alarm.
13. Turn the power on. Press the push-to-run button and verify operation with your amp meter clipped onto the black wire (L2). Close and lock panel.

Figure 11

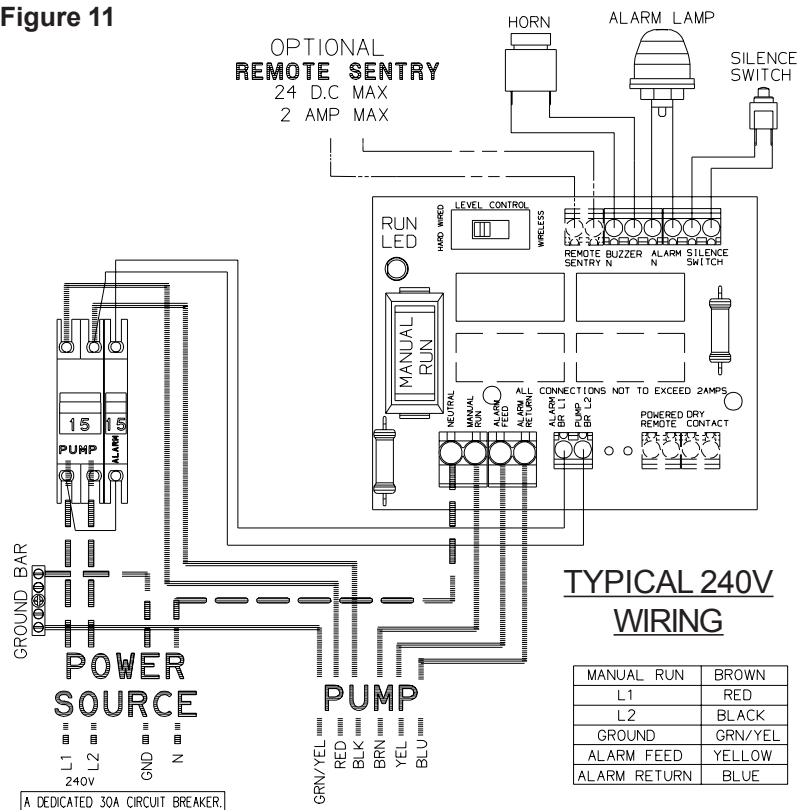

# User Instructions for the Environment One Grinder Pump

Congratulations on your Environment One grinder pump investment. With proper care and by following a few guidelines, your grinder pump will give you years of dependable service.

## General Information

In order to provide you with suitable wastewater disposal, your home is served by a low pressure sewer system. The key element in this system is an Environment One grinder pump. The tank collects all solid materials and effluent from the house. The solid materials are then ground to a small size suitable for pumping as a slurry with the effluent water. The grinder pump generates sufficient pressure to pump this slurry from your home to the wastewater treatment receiving line and/or disposal plant.

This device complies with Part 15 of the FCC rules. Operation is subject to the following two conditions: 1) this device may not cause harmful interference; and 2) this device must accept any interference received, including interference that may cause undesired operation. Any changes or modifications not expressly approved by the party responsible for compliance could void the user's authority to operate this equipment.

## Care and Use of your Grinder Pump

The Environment One grinder pump is capable of accepting and pumping a wide range of materials. Regulatory agencies advise that the following items should not be introduced into any sewer, either directly or through a kitchen waste disposal unit:

Glass	Seafood shells	Diapers, socks, rags or cloth
Metal	Plastic objects (toys, utensils, etc.)	Kitty litter
Goldfish stone	Sanitary napkins or tampons	

In addition, you must **never** introduce into any sewer:

Explosives	Strong chemicals	Lubricating oil and/or grease
Flammable material	Gasoline	

## Periods of Disuse

If your home or building is left unoccupied for longer than a couple of weeks, perform the following procedure:

**Purge the System.** Run clean water into the unit until the pump activates. Immediately turn off the water and allow the grinder pump to run until it shuts off automatically.

**Duplex Units.** Special attention must be taken to ensure that both pumps turn on when clean water is added to the tank.

**Caution: Do not disconnect power to the unit**

## Power Failure

Your grinder pump cannot dispose of wastewater without electrical power. If electrical power service is interrupted, keep water usage to a minimum.

## Pump Failure Alarm

Your Environment One grinder pump has been manufactured to produce an alarm signal (120 volt) in the event of a high water level in the basin. The installer must see that the alarm signal provided is connected to an audible and/or visual alarm in such a manner as to provide adequate warning to the user that service is required. During the interim prior to the arrival of an authorized service technician, water usage must be limited to the reserve capacity of the tank.

**For service, please call your local distributor:**



## Limited Warranty

For IH091

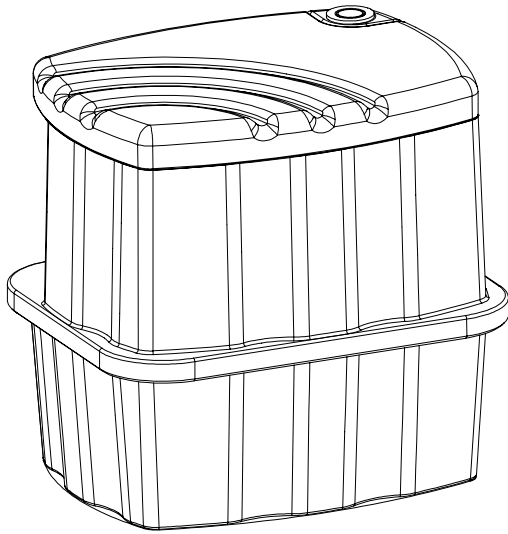

Environment One Corporation offers a limited warranty that guarantees its product to be free of defects in material and factory workmanship for a period of five years from the date of installation, or 63 months from the date of shipment, whichever comes first, provided the product is properly installed, serviced and operated under normal conditions and according to manufacturer's instructions. Repairs or replacement parts required as a result of such defect will be made free of charge during this period upon return of the defective parts or equipment, freight prepaid and allowed, to the manufacturer or its nearest authorized service center.

Model Number: \_\_\_\_\_

Serial Number: \_\_\_\_\_

Installation Date: \_\_\_\_\_



2773 Balltown Rd • Niskayuna NY USA 12309  
(01) 518.346.6161 • [www.eone.com](http://www.eone.com)  
A Precision Castparts Company



NA0066P01 Rev A  
2/09