

**WH48 & WR48  
Series  
Simplex, Duplex,  
Triplex & Quadplex  
Typical Installation  
Instructions &  
Warranty Information**

---

**486-Gal. Capacity  
Grinder Pump Station**

# Environment One Grinder Pump Feature Identification

1. **GRINDER PUMP BASIN** – Polyethylene, with fiberglass accessway section (model height 92” and taller).
2. **ACCESSWAY COVER** – Hinged aluminum.
3. **ELECTRICAL QUICK DISCONNECT (EQD)** – Cable from pump core terminates here.
4. **POWER AND ALARM CABLE** – Circuits to be installed in accordance with local codes.
5. **ALARM PANEL** – NEMA 4X enclosure and equipped with circuit breakers. Locate according to local codes.
6. **ALARM DEVICE** – Every installation is to have an alarm device to alert the homeowner of a potential malfunction. Visual devices should be placed in very conspicuous locations.
7. **INLET** – EPDM grommet (4.5” ID). For 4.5” OD DWV pipe (standard).
8. **WET WELL VENT** – 2.0” tank vent.
9. **GRAVITY SERVICE LINE** – 4” DWV, (4.5 OD). Supplied by others.
- 9a. **STUB-OUT** – 4” X 5’ long **watertight** stub-out, to be installed at time of burial unless the gravity serviceline is connected during installation. Supplied by others.
10. **DISCHARGE FTG** – 1-1/4” Female NPT, stainless steel.
11. **DISCHARGE LINE** – 1-1/4” Nominal pipe size. Supplied by others.
12. **CONCRETE ANCHOR** – See Ballast Calculations for specific weight for your station height. Supplied by others.
13. **BEDDING MATERIAL** – 6” minimum depth, round aggregate, (gravel). Supplied by others.
14. **FINISHED GRADE** – Grade line to be 1” to 2” below station lid and slope away from the station.
15. **CONDUIT** – 1” or 1-1/4”, material and burial depth as required per national and local codes. Conduit must enter panel from bottom and be sealed per NEC section 300.5 & 300.7. Supplied by others.
16. **REBAR** – For use with precast concrete ballast. Required to lift tank after ballast (concrete anchor) has been attached, 4 places, evenly spaced around tank.

Figure 1

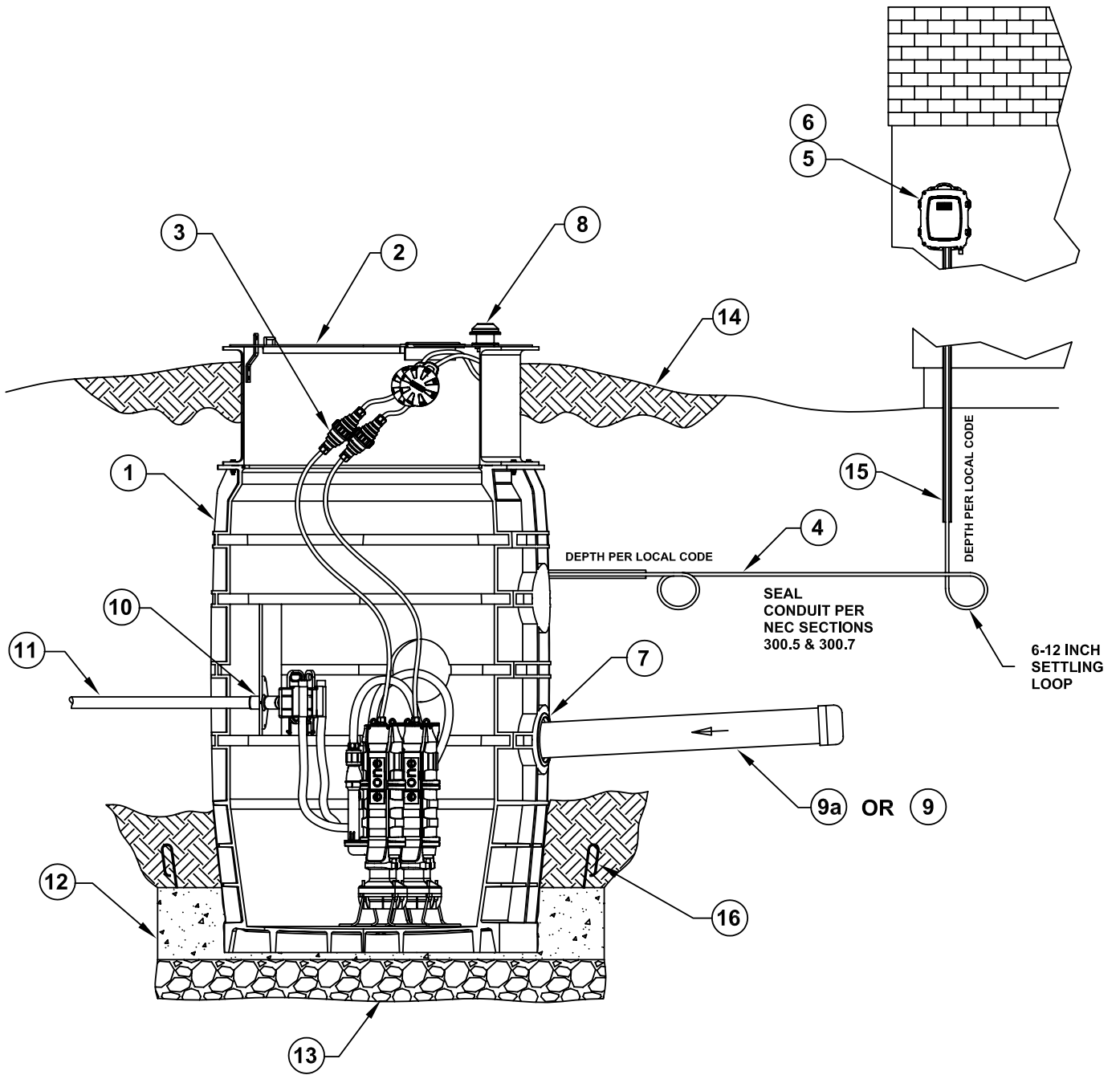

**FAILURE TO COMPLY  
WITH INSTALLATION  
INSTRUCTIONS WILL  
VOID WARRANTY**

The following instructions define the recommended procedure for installing the Model WH/WR48 grinder pump station.

This is a sewage handling pump and must be vented in accordance with local plumbing codes. This pump is not to be installed in locations classified as hazardous in accordance with National Electric Code, ANSI / NFPA 70. All piping and electrical systems must be in compliance with applicable local and state codes.

**1. REMOVE PACKING**

**MATERIAL:** The User Instructions must be given to the owner. Hardware supplied with the unit, if any, will be used at installation.

**2. TANK INSTALLATION:**

The tank is typically supplied with a standard grommet for connecting the 4" DWV (4.50" outside dia.) incoming sewer drain. Other inlet types and sizes are optional. **CAUTION:** 4" DR-35 pipe has a smaller diameter and won't create a watertight joint with the standard 4" SCH 40 inlet grommet. Confirm that you have the correct inlet before continuing. **Do not drop, roll, or lay tank on its side. This will damage the unit and void the warranty.**

Excavate a hole to a depth so that the station cover extends 1" to 2" above the finished grade line. The finished grade must slope away from the station cover to prevent surface water from entering the station. The diameter of the hole shall be large enough to allow for the concrete ballast anchor. The size, shape and shoring requirements of the excavation will be based on

Figure 2a

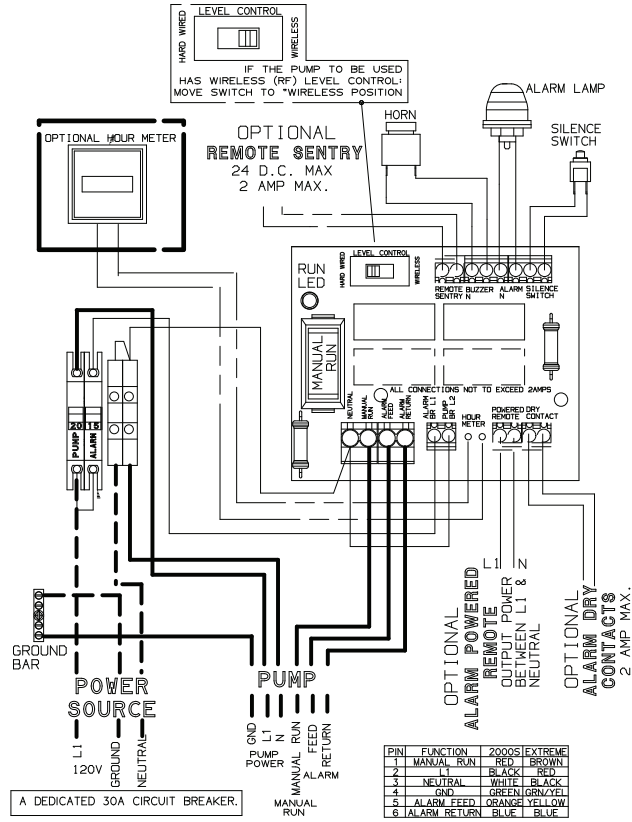

**120 VOLT WIRING – SIMPLEX**

Figure 2b

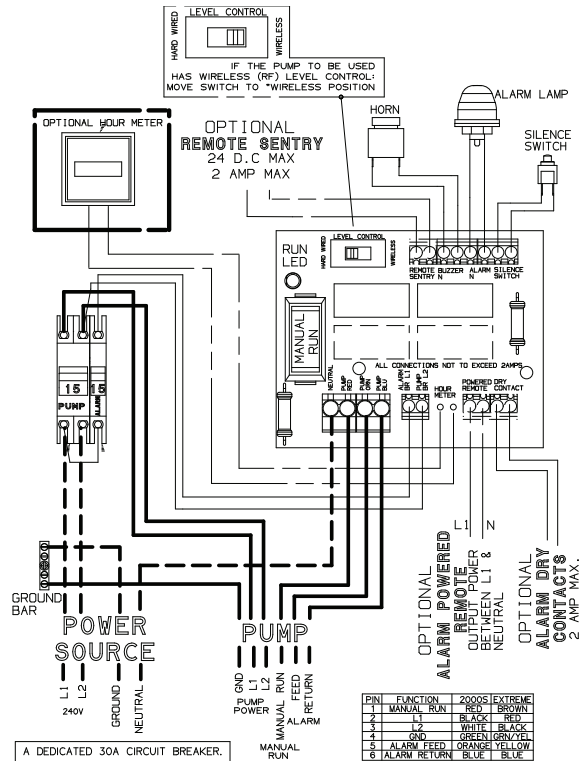

**240 VOLT WIRING – SIMPLEX**

Figure 2d

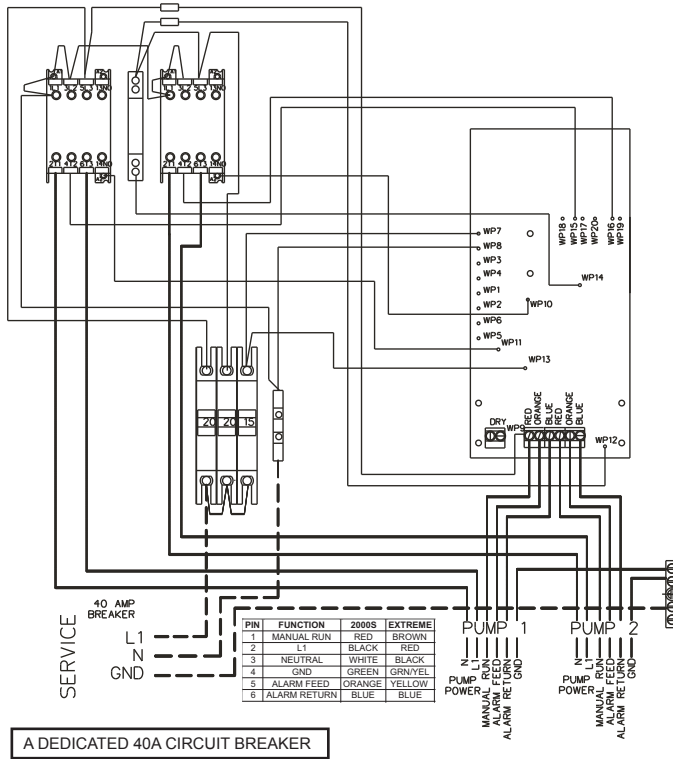

## 120 VOLT DUPLEX WIRING

Figure 2d

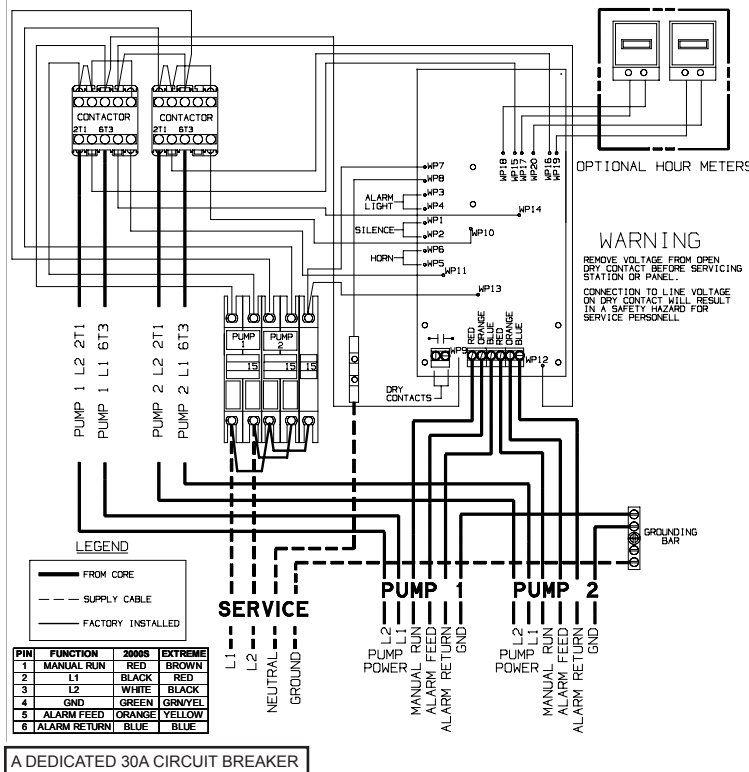

## 240 VOLT WIRING - DUPLEX

the soil conditions and must be in accordance with the site engineer's recommendation and safety requirements. Care must be taken during lifting and placement to prevent impacting or otherwise damaging the tank (see Lifting Instructions). Only a non-marring sling, rated for the load being lifted, should be used in contact with the tank surfaces. A pre-ballasted tank must not be lifted with a sling (see Lifting Instructions). Lifting chains or cables should not be placed in direct contact with the tank surfaces. Fill the excavation bottom with a 6" deep bed of gravel, naturally rounded aggregate, clean and free flowing, with particles not less than 1/8" or more than 3/4" in size.

A concrete ballast anchor is required to prevent flotation of the tank when groundwater is present. The concrete anchor is not optional. The **MINIMUM** concrete anchor requirements for the WH/WR48 station are shown in Chart 1 of the Ballast Calculation section in this manual. Pour approximately 1" to 2" of concrete onto the gravel bed and place the tank into the excavation. Ensure the tank is properly positioned in the excavation to support inlet pipe (Section 3) and discharge pipe (Section 5) connections before pouring the concrete ballast. The unit should be leveled and filled with water, about 24" deep, to prevent shifting while the remaining ballast is being poured. The concrete should be vibrated, as necessary, to eliminate voids. If it is necessary to pour the concrete above the inlet level (Section 3), the inlet must be sleeved with an 8" tube before

pouring.

Concrete ballast should be cast in-place around the tank in the excavation (Figure 3). Alternatively, pre-cast ballast around the base of the tank, may be used. Ensure that 1" to 2" of concrete is placed beneath the tank base if pre-cast ballast is used. If the concrete is pre-cast, lifting hooks must be anchored in the ballast to support subsequent handling of the tank (see Lifting Instructions). The lifting hooks used must be adequate to support the combined weight of the tank and concrete ballast and shall be sized and installed in accordance with the site engineer's recommendation. **Place the ballasted tank on the gravel bedding in the excavated hole using the lifting hooks. Do not lift by any of the tank surfaces if pre-cast ballast is utilized.**

### 3. INLET LOCATIONS:

A 4" DWV (standard) inlet grommet was provided with the station for sealing the

inlet pipe at the tank wall. If the inlet grommet penetration was not factory installed, the location of the tank inlet must be determined to support final positioning of the tank prior to ballast installation (see Section 2). The inlet pipe location corresponds with the actual or projected point where the building sewer line intersects the tank wall. The grade of the inlet pipe and required burial depth (per national and local code requirements) must be accounted for when determining the inlet location. The supply cable path should be considered when selecting the inlet location (see Section 8). A 5" diameter field penetration of the tank wall is required to support installation of the (standard) inlet grommet. This penetration must not remove or interfere with any of the structural ribbing on the polyethylene tank. The inlet grommet may be installed in any of the allowable locations shown in Figure 7. The inlet

penetration **must** be centered in the location selected to prevent interference with the tank ribbing. Typical inlet installation will be on one of the four, 10.5" diameter raised pads on the tank body. The pads have been marked with a series of locating lines to support centering of the 5" (standard) drilled penetration. Any inlet installed in the depressed panels between the horizontal and vertical ribbing must be centered within the panel to provide adequate clearance for the 6" diameter flange on the standard 4" inlet grommet (Figure 7). Once the location of the inlet penetration is selected, mark the inlet center location on the tank and position the tank. Using a 5" diameter hole saw for a standard 4" grommet, drill through the tank wall at the marked location. Remove any chips or burrs from the drilled hole. Install the provided inlet grommet into the drilled hole. The grommet is self-sealing

Figure 3

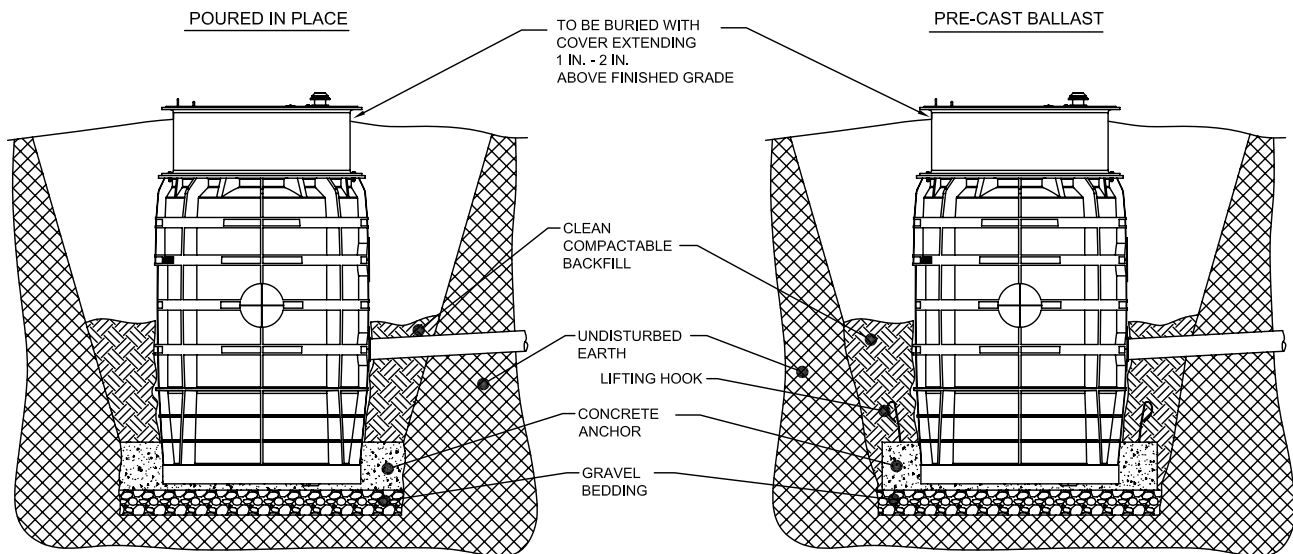

## TYPICAL IN-GROUND SECTION VIEW

and does not require the use of additional sealant or adhesive.

#### 4. INLET PIPE

**INSTALLATION:** Mark the inlet pipe 3.5" from the end to be inserted. Inlet pipe leading edge should be beveled with a grinder and lubricated with a soap solution. Lubricate the inlet grommet with soap solution as well. Insert the pipe into the grommet up to the 3.5" mark. Inspect to ensure the grommet has remained intact and in place (Figure 7).

**5. DISCHARGE:** The use of 1.25" PVC pressure pipe SCH 40 and polyethylene pipe SDR 11 or SDR 7 are recommended. If polyethylene is chosen, use compression-type fittings to provide a smooth inner passage. It is recommended that a Redundant Check Valve Assembly (E/One part no. PC0051GXX) be installed between the pump discharge and the street main on all installations. Never use a ball-

type valve as a check valve. We recommend the valve be installed as close to the public right-of-way as possible. Check local codes for applicable requirements.

**CAUTION:** *Redundant check valves on station laterals and anti-siphon/check valve assemblies on grinder pump cores should not be used as system isolation valves during line tests.*

There is a slide face valve(s) and a quick disconnect(s) pre-installed in the tank for each grinder pump connection. There is a stainless steel 1.25" NPT female discharge connection(s) on the outside of the tank to support discharge piping connection.

Note: Models 481 and 482 will have single discharge pipe connection; models 483 and 484 will have two discharge pipe connections 180 degrees apart (standard).

#### 6. BACKFILL REQUIREMENTS:

Proper

backfill is essential to the long term reliability of any underground structure. Several methods of backfill are available to produce favorable results with different native soil conditions.

The recommended method of backfilling is to surround the unit to grade using Class I or Class II backfill material as defined in ASTM 2321. Class 1A and Class 1B are recommended where frost heave is a concern; Class 1B is a better choice when the native soil is sand or if a high, fluctuating water table is expected. Class I, angular crushed stone, offers an added benefit in that it needs minimal compaction. Class II, naturally rounded stone, may require more compactive effort, or tamping, to achieve the proper density.

If the native soil condition consists of clean compactible soil, with less than 12% fines, free of ice, rocks, roots, and organic material, it may be an acceptable backfill. Such soil must be compacted in lifts not to exceed one foot to reach a final Proctor Density between 85% and 90%. Non-compactible clays and silts are **not** suitable backfill for this or any underground structure such as inlet or discharge lines. If you are unsure of the consistency of the native soil, it is recommended that a geotechnical evaluation of the material be obtained before specifying backfill.

Another option is the use of a flowable fill (i.e., low slump concrete). This is particularly attractive when installing grinder pump stations in

Figure 4

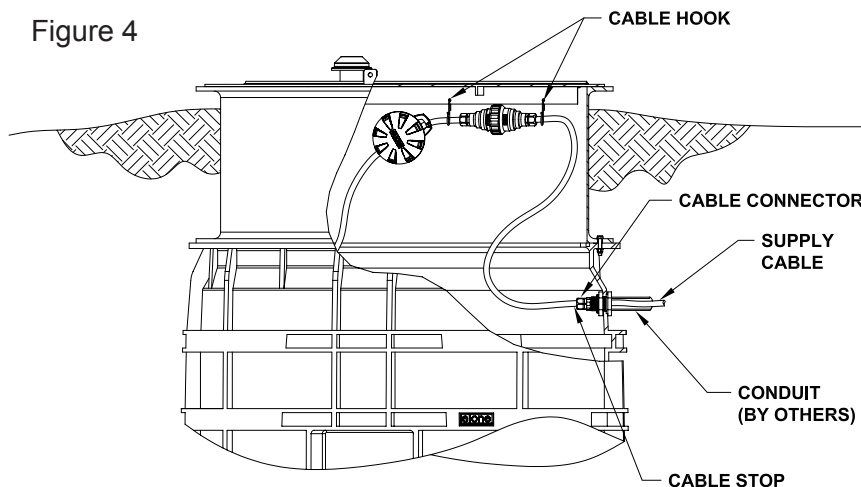

Power at the station must not drop below 10% of nameplate voltage. Maximum Recommended Length:  
 120 Volt 60' (min. voltage at pump — 108V)  
 240 Volt 150' (min. voltage at pump — 216V)  
 Consult factory for longer lengths

## TYPICAL SUPPLY CABLE CONFIGURATION

Figure 5

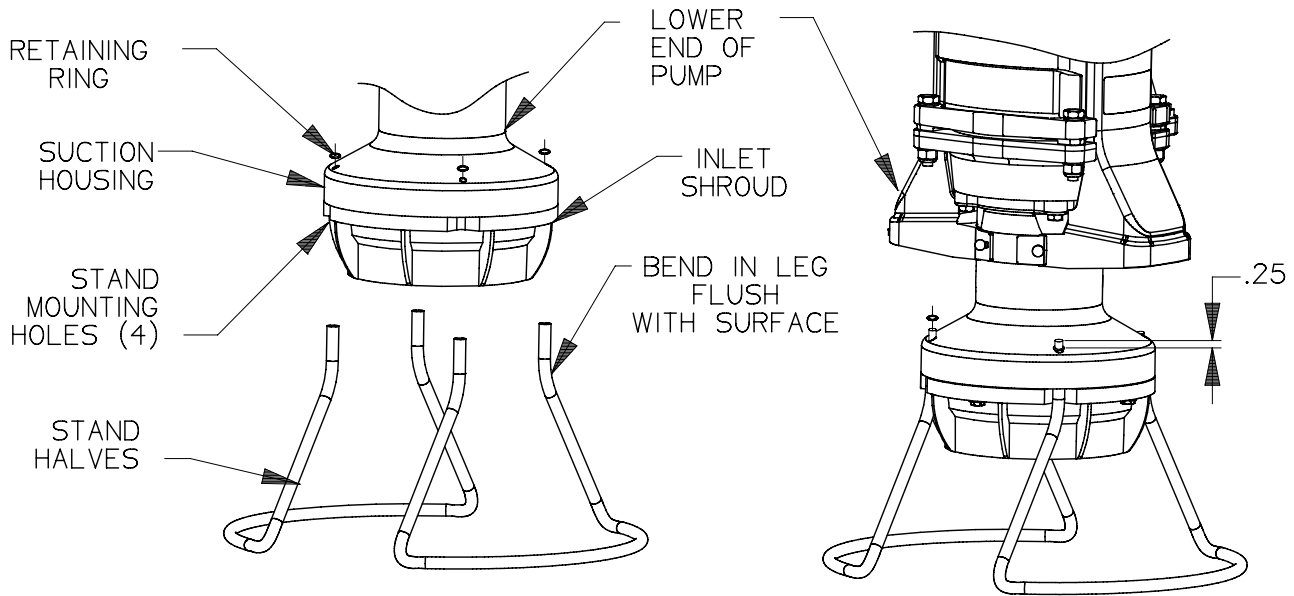

## GRINDER PUMP STAND

augured holes where tight clearances make it difficult to assure proper backfilling and compaction with dry materials. Flowable fills should not be dropped with more than four feet between the discharge nozzle and the bottom of the hole since this can cause separation of the constituent materials.

**7. VENTING:** The unit must be properly vented to assure correct operation of the pump.

The units are supplied with a 2" vent opening in the cover assembly. Failure to *properly vent* the tank will result in faulty operation and will void the warranty.

If the water level outside of the station is expected to rise above the surrounding grade (flooding), a cover vent system cannot be used. If flood conditions are expected, an underground (lateral) vent system and solid cover must be used. **Consult the factory if flood conditions are possible where the station will be**

installed.

### 8. ELECTRICAL CONNECTION: (Supply panel to E/One alarm panel)

Before proceeding, verify that the service voltage is the same as the motor voltage shown on the name plate. An alarm device is to be installed in a conspicuous location where it can be readily seen. An alarm device is required on every installation. There shall be no exceptions.

Wiring of supply panel and alarm panel shall be per Figures 2a–2d, alarm panel wiring diagrams provided with the panel and local codes.

**9. ELECTRICAL CONNECTION: (Pump to Panel) (Fig. 4)** The grinder pump station is provided with a cable for connection between the station and the alarm panel (supply cable) for each grinder pump. The supply cable, a six conductor tray cable, meets NEC requirements for direct burial as long as a minimum of 24" burial depth is maintained.

Those portions of the cable which have less than 24" of cover must be contained in suitable conduit. This includes any vertical portion dropping to a 24" depth at the station and the length rising out of the ground at the control panel (conduit by others). *NOTE: Wiring must be installed per national and local codes. Conduit must enter panel from bottom and be sealed per NEC section 300.5 & 300.7.*

### 9a. Installing E/One supply cable:

1) Open the lid of the station and locate the cable and the feed-thru connector(s) on the inside wall of the tank. For each supply cable, loosen the nut on the connector and pull the supply cable out through the connector until it hits the crimped on stop feature on the cable, approximately 36" from the EQD. **\*\*IMPORTANT:** *All but 36" of the cable must be pulled out of the station, and the Equalizer and EQD should be secured in the hook*

provided to ensure that the pump functions properly. **Do not leave the excess cable in the station.**

2) Retighten the nut. This connection must be tight or ground water will enter the station.

3) Feed the wire through the length of conduit (contractor provided), which will protect it until it is below the 24" burial depth.

4) Run the cable underground, in a trench or tunnel, to the location of the E/One panel. Leave a 6" to 12" loop of cable at each end to allow for shifting and settling. Connections made at the panel are shown in the wiring diagram provided with the E/One panel (Figures 2a–2d).

**10. GRINDER PUMP STAND ASSEMBLY:** Temporarily rest each grinder pump on its side. Using a block of wood or similar object, prop up the lower pump end to allow installation of the pump stand. Align the two legs of each pump stand half with two of the holes in the pump lower end (Figure 5). Push the stand legs into the pump lower end. Using a mallet, ensure that the stand legs bottom into the mounting holes. Repeat for the other stand half. Turn the pump upright on the installed stand.

**11. DEBRIS REMOVAL:** Prior to start-up test procedure, the incoming sewer line must be flushed to force all miscellaneous debris into the tank. Next, all liquid and debris must be removed. Once the tank is clean, install the pump(s) and proceed with the test.

**12. INSTALL THE PUMP:**

Lower the pump(s) into the

tank. Position the pump so the pump's discharge is on the opposite side of the pump relative to the discharge in the tank. Position the pump in the center of the tank. Rotate to coil the discharge hose and slide the adapter on the discharge hose into the receiver in the tank wall until it seats. Push the white slider down to open the discharge valve. Refer to Figures 8–11 for slideface connection and operation.

Hang power cable, breather tubing with Equalizer, and lifting rope to prevent them from laying in sewage. The Equalizer should be hung as high as possible in the tank.

**13. TEST PROCEDURE**

The WH/WR48 Series stations will be provided with the following alarm panel arrangements to control station operation:

Each E/One alarm panel will contain a single-pole circuit breaker to control station alarm level functions (visual and audible alarms). The alarm panel will also contain

Model 481	1	Simplex alarm panel
Model 482	1	Duplex alarm panel
Model 483	1	Simplex alarm panel
	1	Duplex alarm panel
Model 484	2	Duplex alarm panels

one (simplex) or two (duplex), circuit breakers to control grinder pump power. The pump circuit breaker(s) will be labeled "PUMP" in the alarm panel.

For each grinder pump in the Model WH/WR48 Series station, perform the following procedure to verify proper installation and operation of the grinder pumps:

a) Make sure that the slide face discharge valve(s) is fully open for each pump connection. This valve(s) must not be closed when the pump is operating. In some installations, there may be a valve, or valves, at the street main that also must be in the open position when the pump is operating.

b) Fill the tank with approximately 200 gallons of water (approximately up to the top of the grinder pump).

c) Turn on the appropriate pump power and alarm circuit breakers, for the grinder pump being tested, in the alarm panel. The grinder pump and alarm should turn on immediately.

d) Monitor the pump and alarm to ensure they are operating correctly. The alarm will shut off at a water level of approximately 18" from the bottom. The grinder pump will shut off at a water level of approximately 14" from the bottom.

e) Turn off the pump power and alarm circuit breakers for the pump tested.

f) Repeat steps A through E for the remaining grinder pumps in the WH/WR48 Series station.

# Field Joint Assembly Instructions

IT IS EXTREMELY IMPORTANT THAT THE JOINT IS SEALED PROPERLY BEFORE BACKFILLING. EXCAVATING A UNIT FOR REPAIR IS VERY EXPENSIVE AND CAN BE EASILY AVOIDED BY USING PROPER CAUTION DURING THE FOLLOWING PROCEDURE.

Parts included in Field Joint Kit:  
Identify all parts before proceeding with installation.

- (16) 3/8-16 X 2" long screws
- (16) 3/8-16 Elastic Stop Nuts
- (32) Flat Washers
- (1) Length Sealant (Sika) Tape
- (1) Hole Punch

1) Carefully clean and dry both accessway flanges and the tank top flange with solvent. **IMPORTANT: Sealing surfaces must be dry to ensure the sealant adheres correctly.**

2) Starting at one hole of tank flange, apply two layers of Sika Tape around the flange. Align the outside edge of the tape with the bolt circle. Move to the adjacent hole and apply one layer of Sika Tape around the outside of the flange. Align inside of tape with the bolt circle. Remove the backing paper as you lay the adhesive on the flange. **Do not stretch Sika tape during application, it may result in a leak.** The tape should overlap at the end by approximately 1/2 inch, as shown in Figure 6a. If a section of Sika Tape is misapplied, the bad section may be cut out and replaced. Cut away the poorly laid portion cleanly with a knife and be sure to overlap the tape at each end about 1/2 inch.

3) Using the tool provided, punch a hole through the tape at each of the 16 existing bolt holes in the flange. **Be careful to keep the exposed sealant clean and dry.**

4) Insert three of the sixteen 3/8-16 x 2" long bolts, with a flat washer, into the flange attached to the lower end of the accessway. These will act as guides while aligning the bolt pattern of the two flanges.

5) Support the upper accessway

section a few inches over the tank. Align the aluminum cover locking hasp on the fiberglass accessway section with the stainless steel discharge connection on the polyethylene tank (Figure 6b). Once aligned, lower the upper section onto the mating flange using the three bolts to guide it to the proper position. See Figure 6c.

6) Insert the remaining 13 bolts with flat washers into the flanges. Place a flat washer and elastic stop nut on the end of each bolt, turning the nut on just enough to hold the washer in place.

7) Tighten up the bolts until the sealant begins to squeeze out from between the flanges. To ensure a consistent, sturdy

seal tighten them in the following sequence: 1, 9; 5, 13; 3, 11; 7, 15; 2, 10; 4, 12; 6, 14; 8, 16. Always be sure to tighten one bolt and then the bolt at the position 180° from it, see Figure 6a for position numbers.

8) Using the same sequence as in step 7 tighten each bolt to 60 in-lbs. Visually inspect the joint, each bolt and each nut should have a flat washer between it and the flange, and a uniform amount of sealant should be protruding from the seam along the entire perimeter.

**In the event that there are any voids in the sealant, the joint may leak. Take corrective actions if necessary and be sure that the joint is leak free before continuing.**

Figure 6a

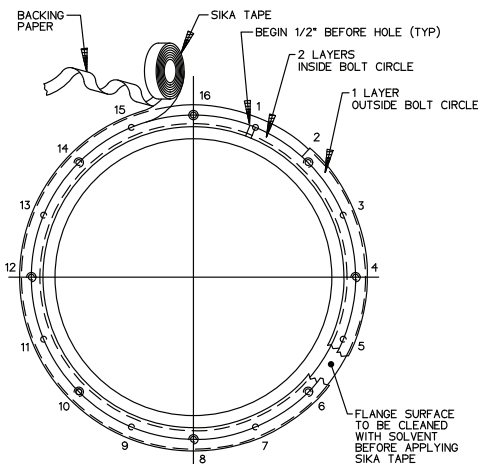

Figure 6c

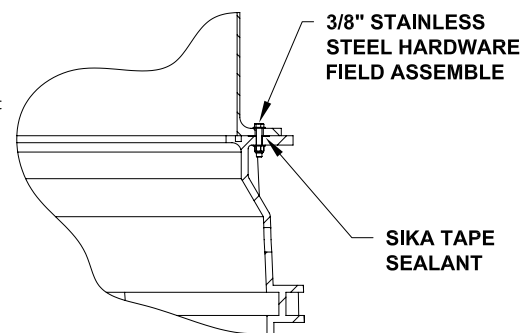

Figure 6b

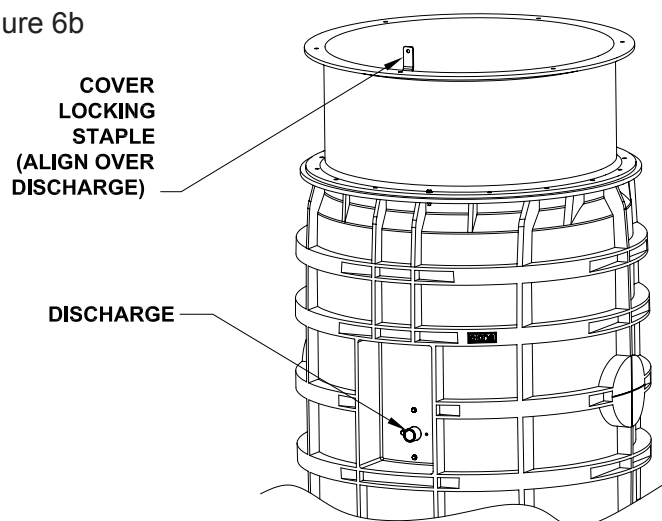
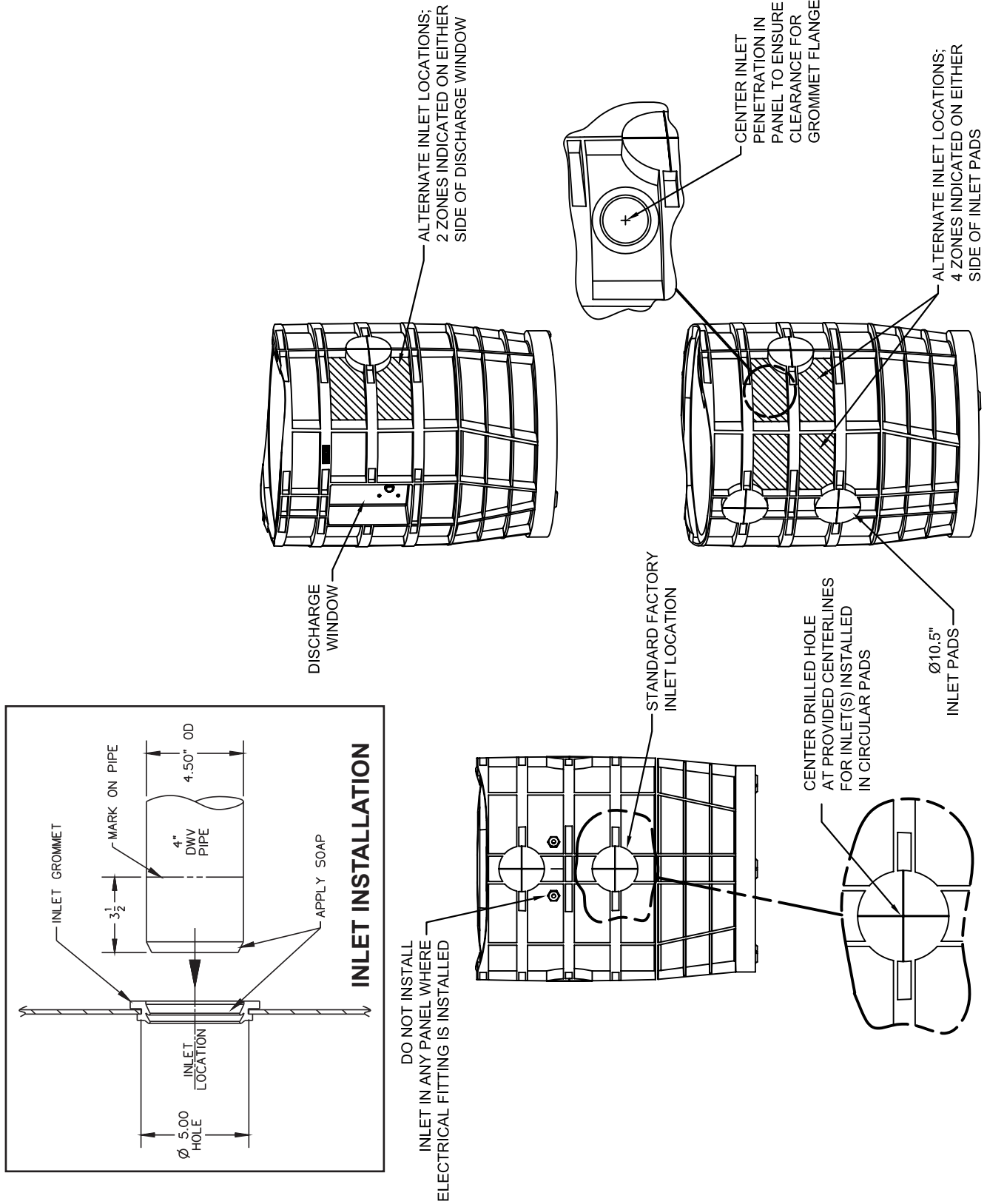

Figure 7



## ALLOWABLE INLET LOCATIONS

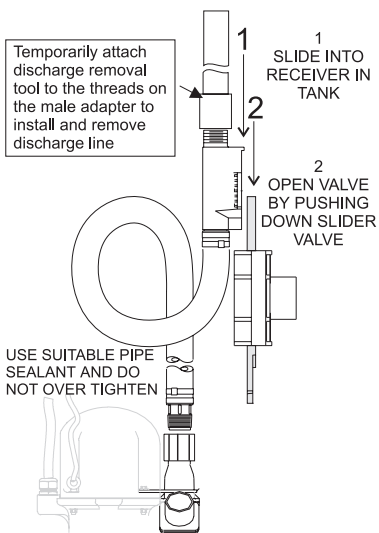

Figure 8

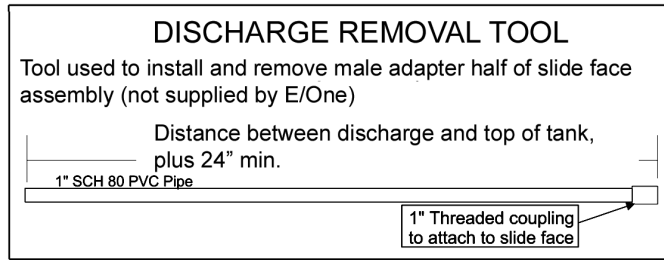

Figure 9

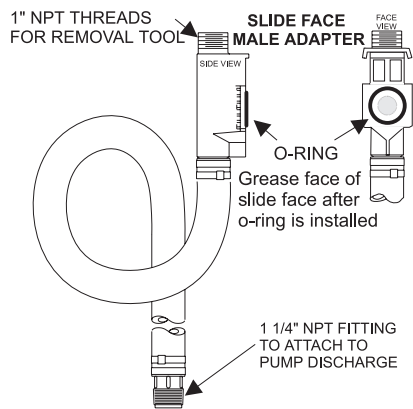

Figure 10

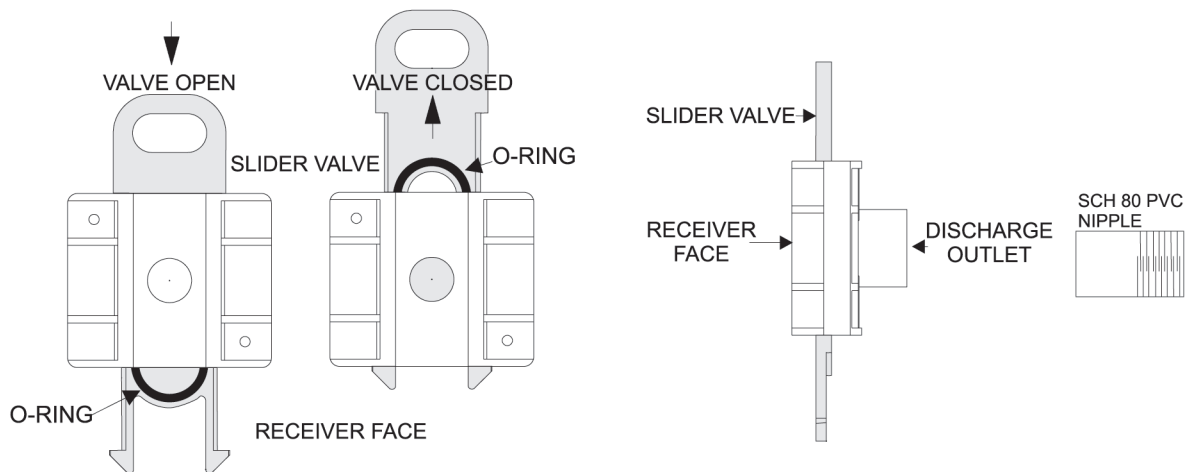

Figure 11

# Lifting Instructions

FAILURE TO FOLLOW THESE INSTRUCTIONS COMPLETELY WILL VOID WARRANTY.

1. Transporting unit to installation site: **Always lift a unit from the bottom for the purpose of transportation. The station should be received attached to a pallet for this purpose.** Never roll a station or move it on its side.

2. No Ballast (to be poured in place): If the concrete anchor is in place lift the unit using 2 nylon straps wrapped under the tank flange to make a sling, as shown below. Keep station oriented vertically to avoid any damage.

3. Precast Ballast: Never lift a station that has a ballast attached by any means except the rebar. The weight of the concrete will damage the station if you attempt to lift it from any part of the station.

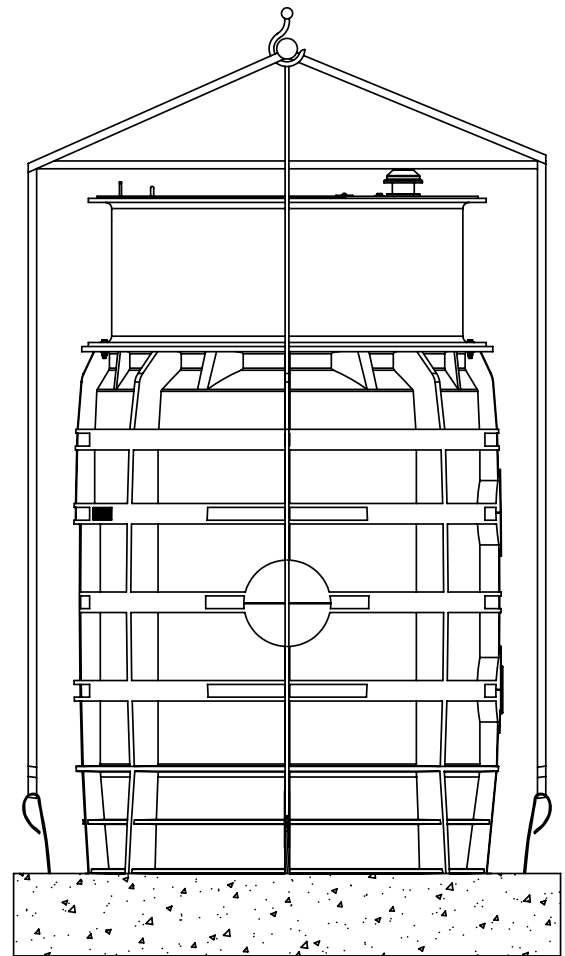
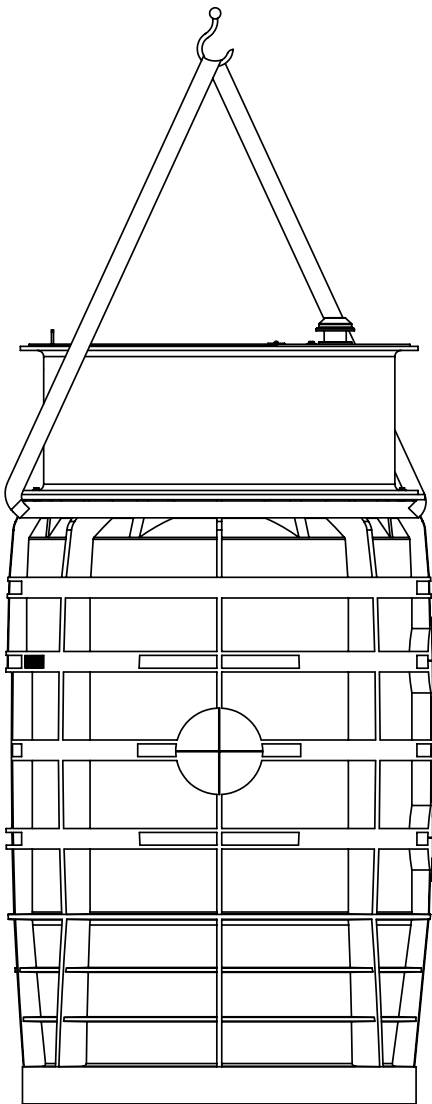

# E/One Grinder Pump Station Ballast Calculations

## Sample Calculation — Station Height of 92”

Volume of Station = 85.1 ft<sup>3</sup>

Station Weight = 440 lbs

Station Height = 7.6 ft

### A. Buoyant Force

1. The buoyant force acting on the submerged WH/WR48 is equal to the weight of the displaced water for the section of the tank that is submerged.

$$\begin{aligned}F_{\text{buoyant}} &= (\text{density of water})(\text{volume of station}) \\ &= (62.4 \text{ lbs/cu ft})(85.1 \text{ cu ft}) \\ &= 5313 \text{ lbs}\end{aligned}$$

2. The net buoyant force acting on the station ( $F_{\text{net-buoyant}}$ ) is equal to the buoyant force ( $F_{\text{buoyant}}$ ) minus the weight of the station tank.

$$\begin{aligned}F_{\text{net-buoyant}} &= 5313 \text{ lbs} - 440 \text{ lbs} \\ &= 4873 \text{ lbs}\end{aligned}$$

### B. Ballast Force

1. Determine the volume of concrete and soil

Section I: Used To Determine The Volume Of Concrete

(Note: 4.0 ft = assumed inside diameter of concrete ballast ring around tank's bottom flange)

$$\begin{aligned}\text{Volume} &= (\text{Height})(\text{Area}) \\ &= (.83 \text{ ft})(\pi)((5.6 \text{ ft})^2 - (4.0 \text{ ft})^2) / 4 \\ &= (.83 \text{ ft})(12.06 \text{ ft}^2) \\ &= 10.1 \text{ ft}^3\end{aligned}$$

Section II: Used To Determine The Volume Of Saturated Soil

(Note: 4.3 ft = assumed inside diameter of soil column around tank's maximum diameter)

$$\begin{aligned}\text{Volume} &= (\text{Height})(\text{Area}) \\ &= (7.6 \text{ ft} - .83 \text{ ft})(\pi)((5.6 \text{ ft})^2 - (4.26 \text{ ft})^2) / 4 \\ &= (6.7 \text{ ft})(10.1 \text{ ft}^2) \\ &= 67.7 \text{ ft}^3\end{aligned}$$

2. Determine the combined ballast

$$\begin{aligned}\text{Ballast (total)} &= \text{Ballast (concrete)} + \text{Ballast (saturated soil)} \\ &= (V_{\text{concrete}})(\text{density concrete in water}) + (V_{\text{soil}})(\text{density saturated soil}) \\ &= (10.1 \text{ ft}^3)(87.52 \text{ lbs/ft}^3) + (67.7 \text{ ft}^3)(70 \text{ lbs/ft}^3) \\ &= 884 \text{ lbs} + 4739 \text{ lbs} \\ &= 5623 \text{ lbs}\end{aligned}$$

- C. Subtract the buoyant force from the ballast force to determine the final condition

$$\begin{aligned}\text{Final Condition} &= \text{Ballast Force} - \text{Net Buoyant Force} \\ &= 5623 \text{ lbs} - 4873 \text{ lbs} \\ &= 750 \text{ lbs (excess ballast)}\end{aligned}$$

# E/One Grinder Pump Station Ballast Calculations

## Sample Calculation

The approach outlined on the previous page may be used to calculate the ballast requirements listed below.

Chart 1

Station Height (in)	Station Volume (cu ft)	F <sub>net</sub> Buoyant (lbs)	Tank Weight (lbs)	F <sub>ballast</sub> (lbs)	Volume Concrete (cu ft)*	Weight Concrete in Air (cu ft)*	Min Diameter of Concrete Anchor (in)	Min Thickness of Concrete Anchor (in)
75	71.6	4088	380	4706	10.1	1515	68	10
92	85.1	4873	440	5623	10.1	1515	68	10
98	90.1	5175	445	5980	10.1	1515	68	10
104	95.0	5478	450	6330	10.1	1515	68	10
110	99.9	5780	455	6687	10.1	1515	68	10
116	104.8	6083	460	7037	10.1	1515	68	10
122	109.8	6385	465	7394	10.1	1515	68	10

\* Volume calculated is for minimum dimensions given. Minimum dimensions must be met or exceeded for actual application.

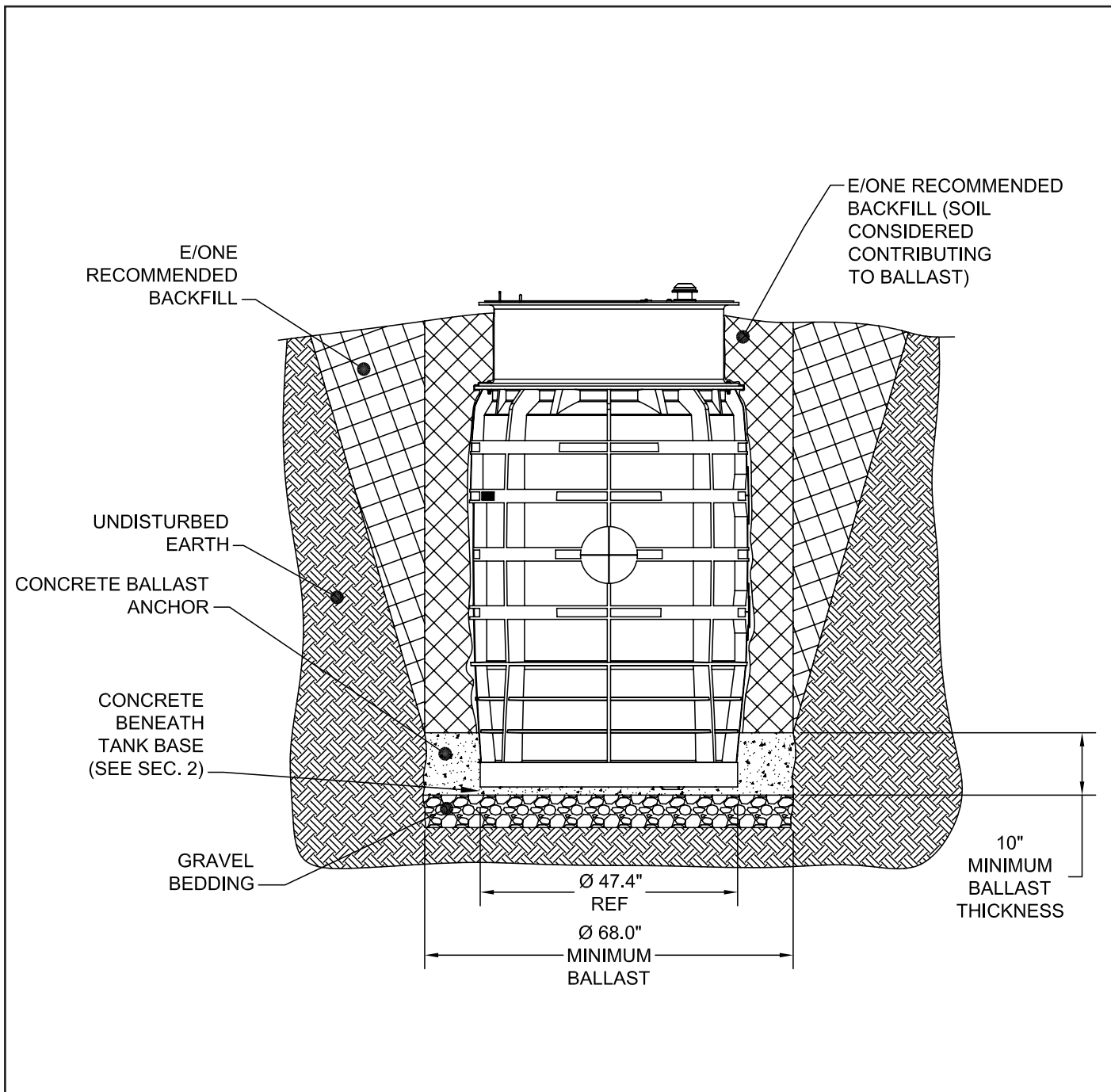

## BALLAST INFORMATION





*A Precision Castparts Company*

---

Environment One Corporation  
2773 Balltown Road  
Niskayuna, New York 12309-1090

Voice: (01) 518.346.6161  
Fax: 518.346.6188

[www.eone.com](http://www.eone.com)

NA0251P01 Rev B  
3/12

# User Instructions for the Environment One Grinder Pump

Congratulations on your Environment One grinder pump investment. With proper care and by following a few guidelines, your grinder pump will give you years of dependable service.

## General Information

In order to provide you with suitable wastewater disposal, your home is served by a low pressure sewer system. The key element in this system is an Environment One grinder pump. The tank collects all solid materials and effluent from the house. The solid materials are then ground to a small size suitable for pumping as a slurry with the effluent water. The grinder pump generates sufficient pressure to pump this slurry from your home to the wastewater treatment receiving line and/or disposal plant.

This device complies with Part 15 of the FCC rules. Operation is subject to the following two conditions: 1) this device may not cause harmful interference; and 2) this device must accept any interference received, including interference that may cause undesired operation. Any changes or modifications not expressly approved by the party responsible for compliance could void the user's authority to operate this equipment.

## Care and Use of your Grinder Pump

The Environment One grinder pump is capable of accepting and pumping a wide range of materials. Regulatory agencies advise that the following items should not be introduced into any sewer, either directly or through a kitchen waste disposal unit:

Glass	Seafood shells	Diapers, socks, rags or cloth
Metal	Plastic objects (toys, utensils, etc.)	Kitty litter
Goldfish stone	Sanitary napkins or tampons	

In addition, you must **never** introduce into any sewer:

Explosives	Strong chemicals	Lubricating oil and/or grease
Flammable material	Gasoline	

## Periods of Disuse

If your home or building is left unoccupied for longer than a couple of weeks, perform the following procedure:

**Purge the System.** Run clean water into the unit until the pump activates. Immediately turn off the water and allow the grinder pump to run until it shuts off automatically.

**Duplex Units.** Special attention must be taken to ensure that both pumps turn on when clean water is added to the tank.

**Caution: Do not disconnect power to the unit**

## Power Failure

Your grinder pump cannot dispose of wastewater without electrical power. If electrical power service is interrupted, keep water usage to a minimum.

## Pump Failure Alarm

Your Environment One grinder pump has been manufactured to produce an alarm signal (120 volt) in the event of a high water level in the basin. The installer must see that the alarm signal provided is connected to an audible and/or visual alarm in such a manner as to provide adequate warning to the user that service is required. During the interim prior to the arrival of an authorized service technician, water usage must be limited to the reserve capacity of the tank.

**For service, please call your local distributor:**



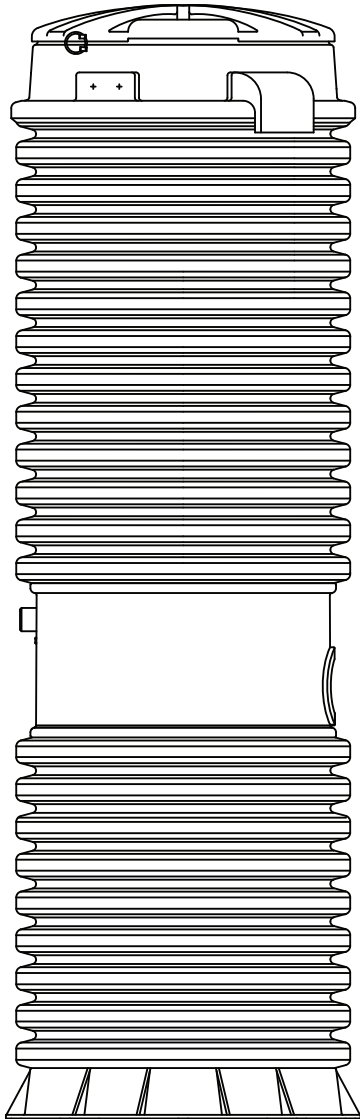

# Limited Warranty

For E/One Extreme D-Series,  
W-Series & Upgrade

Environment One Corporation offers a limited warranty that guarantees its product to be free from defects in material and factory workmanship for a period of two years from the date of installation, or 27 months from the date of shipment, whichever occurs first, provided the product is properly installed, serviced and operated under normal conditions and according to manufacturer's instructions. Repair or parts replacement required as a result of such defect will be made free of charge during this period upon return of the defective parts or equipment to the manufacturer or its nearest authorized service center.

Model Number: \_\_\_\_\_

Serial Number: \_\_\_\_\_

Installation Date: \_\_\_\_\_



2773 Balltown Rd • Niskayuna NY USA 12309  
(01) 518.346.6161 • www.eone.com