

# **WH101F & WR101F Typical Installation Instructions & Warranty Information**

---

**Simplex Station**

# Environment One Grinder Pump Feature Identification

1. **Grinder Pump Basin** – High density polyethylene (HDPE)
2. **Accessway Cover** – Painted steel, marine-grade enamel coated.
3. **Electrical Quick Disconnect (EQD)** – Electrical lead from pump core terminates here (NEMA 6P).
4. **Power and Alarm Lead** – Circuits to be installed in accordance with local codes.
5. **Alarm Panel** – NEMA 4X enclosure. Equipped with circuit breakers or disconnect switch. Locate according to local codes.
6. **Alarm Device** – Every installation is to have an alarm device to alert the homeowner of a potential malfunction. Visual devices should be placed in conspicuous locations.
7. **Inlet** – 4-inch PVC socket (4.5 inches ID). For solvent cementing DWV pipe.
8. **Settling Loop** – Coil wire to protect against soil settling.
9. **Gravity Service Line** – 4-inch DWV (4.5 inches OD). Supplied by others.
- 9a. **Stub-Out** – 4" X 5' long **watertight** stub-out with watertight cap, to be installed at time of burial unless the gravity service line is connected during installation. Supplied by others.
10. **Discharge Outlet** – 1 ¼-inch solvent weld
11. **Discharge Line** – 1 ¼-inch nominal pipe size. Supplied by others.
12. **Concrete Anchor** – See ballast calculations for correct ballast weight. Supplied by others.
13. **Bedding Material** – 6-inch minimum depth, rounded aggregate (gravel). Supplied by others.
14. **Finished Grade** – Grade line should be 2 inches below the cover and slope away from the station.
15. **Conduit** – 1" or 1-1/4", material and burial depth as required per national and local codes. Conduit must enter panel from bottom and be sealed per NEC section 300.5 & 300.7. Supplied by others.
16. **Rebar** – Required to lift tank after ballast has been attached (4 places, evenly spaced around tank).
17. **Vent Port** – 2" PVC solvent weld socket for 2" DWV pipe. Pipe supplied by others.
18. **Vent Line** – 2 inch nominal pipe size. Supplied by others.
- 18a. **Stub-Out** – 2" x 5' long **watertight** stub-out with watertight cap, to be installed at time of burial unless vent line is completed at this time. Supplied by others.
19. **Vent Pipe Screen, SS**
20. **Vent Pipe Nut** – 2" FNPT

**FAILURE TO COMPLY WITH  
INSTALLATION INSTRUCTIONS  
WILL VOID WARRANTY**

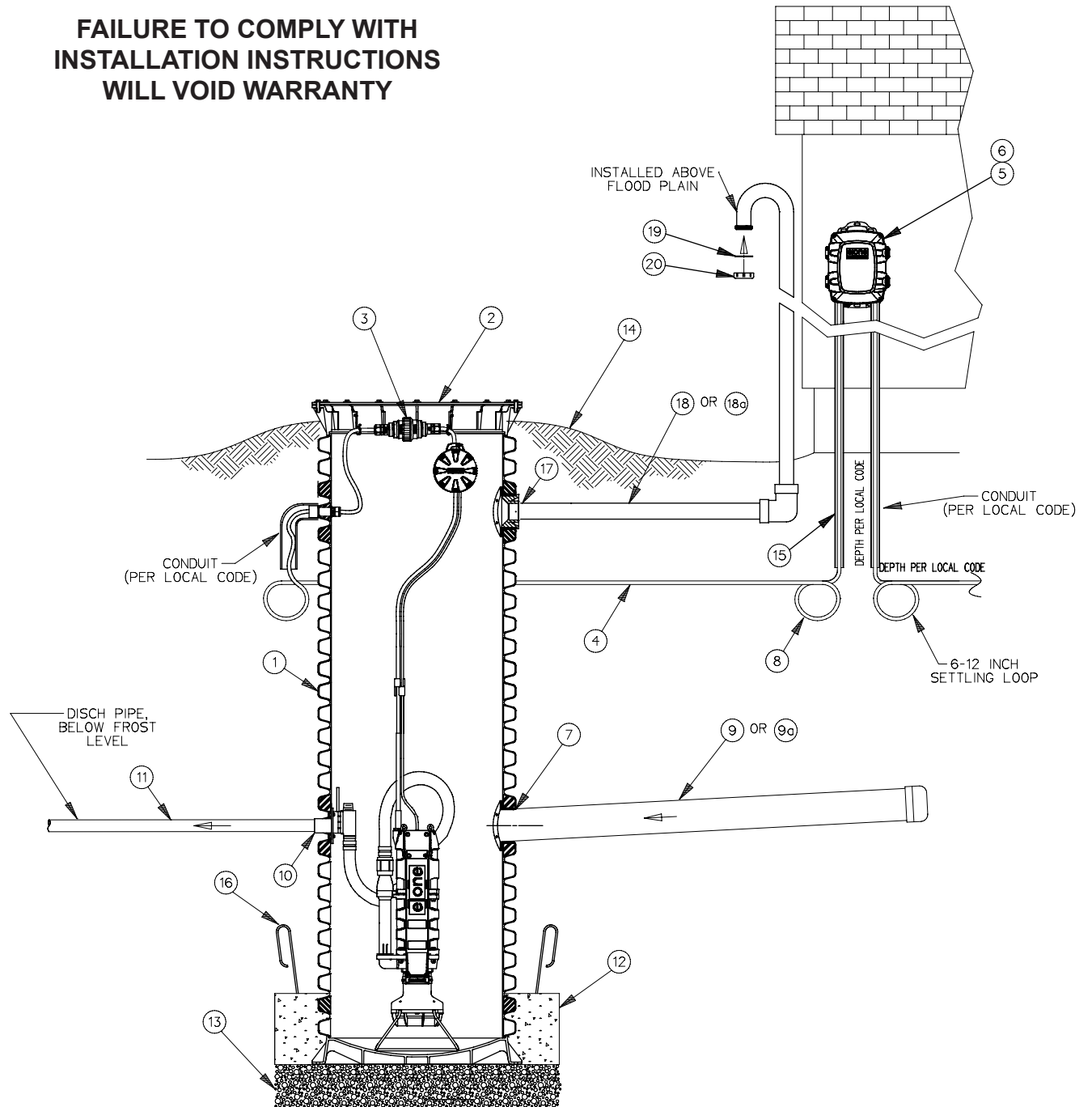

The following instructions define the recommended procedure for installing the Model WH101F grinder pump station. The Model WH101F is a sewage-handling pump station and must be vented in accordance with local plumbing codes. Do not install the unit in locations classified as hazardous in accordance with the National Electric Code, ANSI/NFPA 70. All piping and electrical systems must be in compliance with applicable local and state codes.

### 1. Remove Packing Material

Give the User Instructions to the homeowner. Hardware supplied with the unit, if required, will be used during installation.

### 2. Tank Installation

The tank is supplied with a standard 4-inch PVC DWV (4.5 inches inside dia.) inlet socket for connecting the incoming sewer drain. If a concrete ballast is attached to the tank, lift only by the lifting eyes embedded in concrete. Do not drop, roll or lay the tank on its side. Doing so may damage the unit and void the warranty. Excavate a hole to a depth so the removable cover extends 2 inches above the finished grade line; the grade should slope away from the unit. The diameter of the hole must be large enough to allow a concrete anchor.

Place the unit on a 6-inch bed of gravel, naturally rounded aggregate, clean and free-flowing, with particle size no less than 1/8 inch or more than 3/4 inch in diameter. The concrete anchor is required to keep the unit from floating as a result

of high groundwater levels. The amount of concrete required varies for each unit (see page 10 for the correct ballast weight).

The unit should be leveled and filled with water to the bottom of the inlet; doing so prevents the unit from shifting when pouring the cement. The cement must be manually vibrated to eliminate any voids. If pouring the cement to a level higher than the inlet piping is necessary, place an 8-inch sleeve over the inlet prior to pouring the cement.

### 3. Discharge

Using 1 1/4-inch PVC (SCH-40)

pressure pipe or polyethylene water service tubing (SDR-9, Type PE3206 or PE3306) with a minimum pressure rating of 160 psi is recommended. If polyethylene pipe is chosen, use compression-type fittings to provide a smooth inner passage (insert fittings are susceptible to clogging). Environment One recommends that a redundant check valve be installed between the pump discharge and the street main on all installations. The valve is to be installed as close to the public right-of-way as possible. Check local codes for applicable requirements.

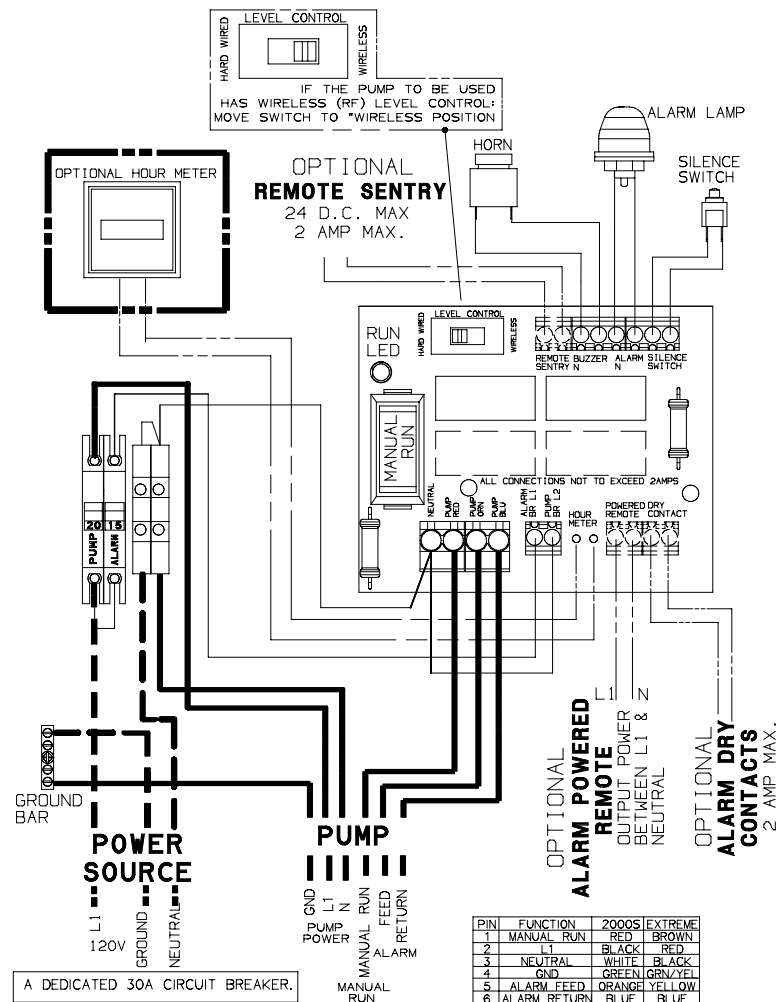

Figure 2a – 120V Simplex

#### 4. Vent

The station must be vented to a height above the expected maximum flood level. Using 2 inch PVC pipe, solvent weld pipe into the PVC socket near the top of the tank. Route pipe above flood level, ensuring the pipe always angles down towards the station so no traps (low spots) are created. Place a gooseneck at the top of the vent to prevent rainwater and other foreign objects from entering the vent. Install factory-provided screen and nut to bottom of gooseneck. Failure to vent the station properly will prevent the station from venting and will void the warranty.

#### 5. Backfill Requirements

Proper backfill is essential to the long-term reliability of any underground structure.

Several methods of backfill are available and each yields favorable results when done properly. Clean, compact, native soil that is free from rocks, roots or organic material may be used if compacted in lifts not to exceed one foot. It must be compacted to a final Proctor density between 85 and 90 percent. Heavy, non-compactable clays are not acceptable backfill for this or any underground structure such as inlet or discharge lines.

Class 1 or Class 2 backfill material as defined by ASTM 2321 may also be used. Crushed stone and gravel backfill materials offer an advantage since they typically reach a compaction level of 90 to 95 percent standard density with minimal compaction.

Another option is flowable fill (i.e., low slump concrete). This is particularly attractive when installing grinder pump stations in augered holes where tight clearances make it difficult to assure proper backfilling and compaction with dry materials. Flowable fills should not be dropped more than four feet from the discharge nozzle to the bottom of the hole since this can cause separation of the constituent materials.

#### 6. Electrical Connection (supply panel to alarm panel)

Before proceeding, verify that the service voltage is the same as the motor voltage shown on the name plate. An alarm device is to be installed in a conspicuous location where it can be readily seen by the home owner. An alarm device is required on every installation. There shall be no exceptions.

Wiring of supply panel and alarm panel shall be per Figure 2a or 2b, alarm panel wiring diagrams and local codes.

#### 7. Electrical Connection (pump to panel)

The cable provided for connection between the station and alarm panel is a six-conductor tray cable that meets NEC requirements for direct burial as long as a minimum of 24

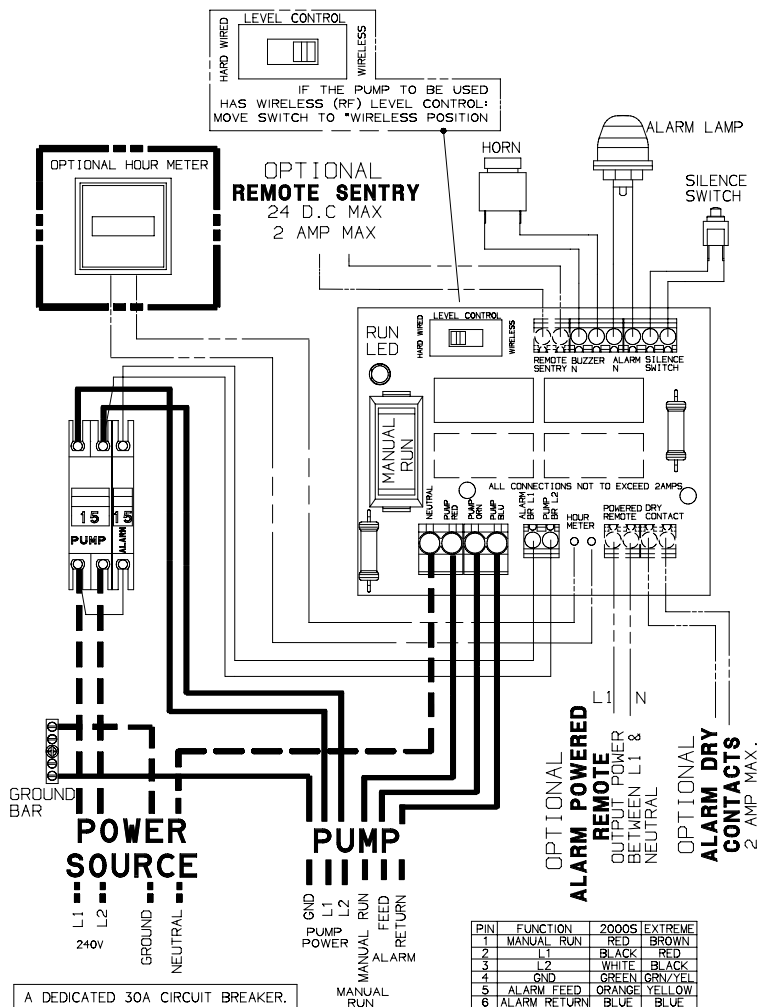

Figure 2b – 240V Simplex

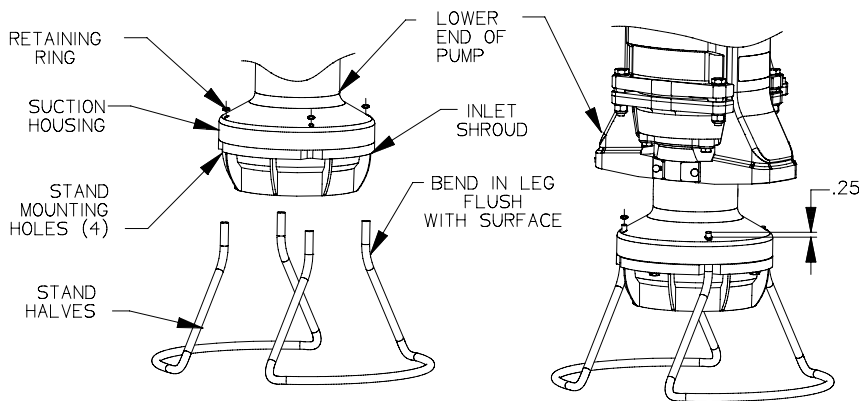

Figure 3

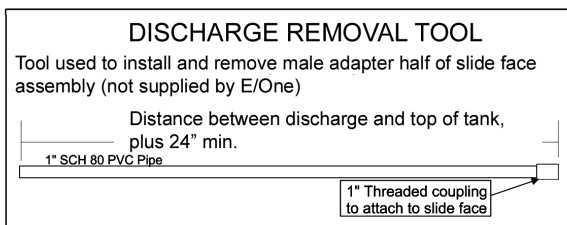

Figure 5

inches of cover is maintained. Those portions of cable that have less than 24 inches of cover must be contained within suitable conduit. This includes the vertical section that drops to a 24-inch depth at the station and the length exiting out of the ground at the control panel. Note: Wiring must be installed in compliance with local codes (which may vary from above). The maximum distance between the pump and panel is 100 feet. **NOTE: Wiring must be installed per national and local codes. Conduit must enter panel from bottom and be sealed per NEC section 300.5 & 300.7.**

Failure to seal conduit may cause premature pump failure and void warranty.

Power source to the panel must be 240 VAC (or 120 VAC for a 120V model). A dedicated 30-amp breaker with ground and separate neutral is required.

### 8. Installing E/One supply cable with EQD:

a. Open the lid of the station, locate the cable and the feed-thru connector on the wall of the tank. Loosen the nut on the connector and pull the supply cable out through the connector until it hits the crimped on stop feature on the cable, approximately 24" from the EQD.

**\*\*IMPORTANT: All but 24" of the cable must be pulled out of the station, and the portion of the cable between the EQD and the molded in cable breather should be secured in**

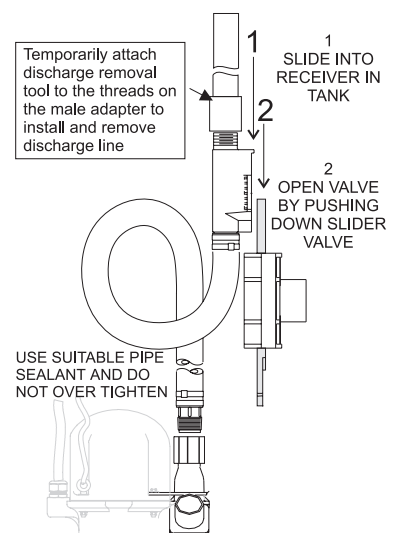

Figure 4

*the hook provided to ensure that the pump functions properly. Do not leave the excess cable in the station.*

b. Retighten the nut. *This connection must be tight or ground water will enter the station.*

c. Feed the wire through the length of conduit (contractor provided) which will protect it until it is below the 24" burial depth.

d. Position the conduit vertically below the cable connector along side of the station reaching down into the burial depth.

Run the cable underground, in a trench or tunnel, to the location of the E/One panel. Leave a 6- to 12-inch loop of cable at each end to allow for shifting and settling. Connections made at the panel are shown in the panel wiring diagram (Fig. 2a and 2b).

### 9. Debris Removal

Before the start-up test procedure, flush the incoming sewer line to force all miscellaneous debris into the tank. Next, remove all liquid and debris.

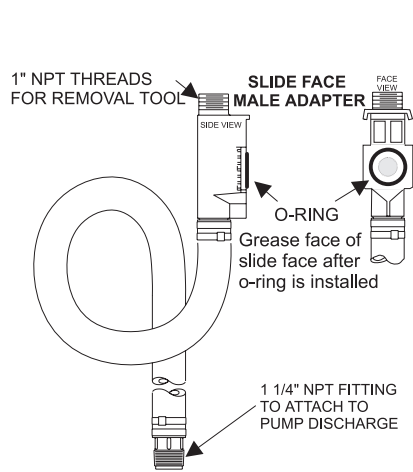

Figure 6

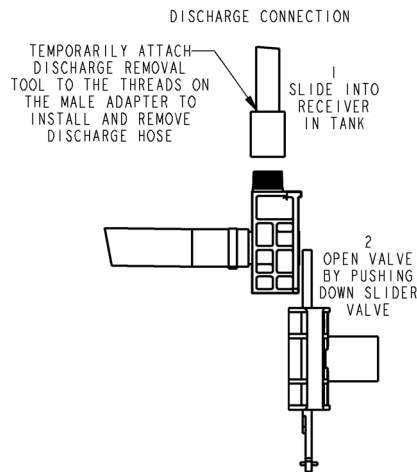

Figure 7

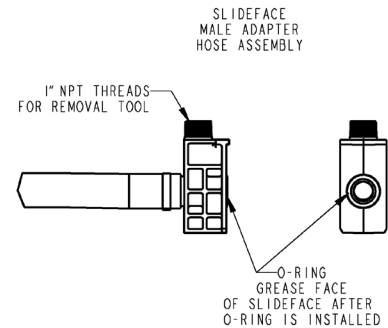

Figure 8

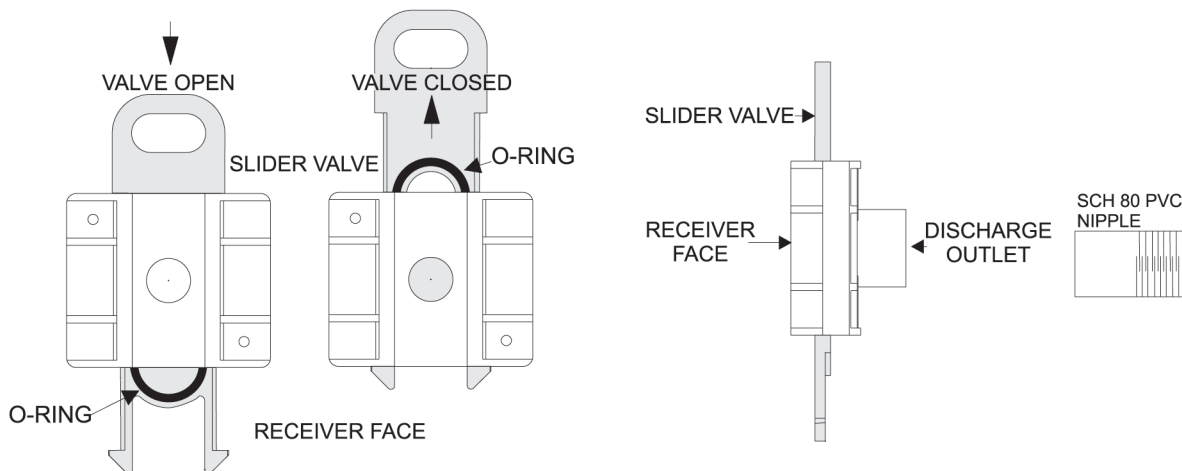

Figure 9

Once the tank is clean, install the pump and test.

### 10. Stand Assembly

Temporarily rest the grinder pump on its side. Using a block of wood or similar object, prop up the lower pump end to allow installation of the pump stand. Align the two legs of each pump stand half with two of the holes in the pump lower end. Push the stand legs into the pump lower end. Using a mallet, ensure that the stand legs bottom into the mounting holes.

Repeat for the other stand half. Turn the pump upright on the installed stand. Install the four retaining rings (included with installation instructions; Fig. 3).

**11. Slide Face Discharge**  
Refer to any documentation that may have shipped with your discharge. Attach the discharge hose to the anti-siphon check valve. Use pipe sealer on threads to ensure leaktightness (Fig. 4). Check the O-ring on the slideface adapter for adequate lubrica-

tion (Fig. 6). Attach discharge installation tool on male adapter (Figs. 4 and 5).

### 12. Pump Installation

Lower the pump into the tank. Position the pump so the pump's anti-siphon check valve is on the opposite side of the pump relative to the discharge in the tank. Position the pump in the center of the tank. Refer to the Installation Layout drawing in the front of this manual.

Rotate discharge hose and

male adapter to create a loop or coil. Slide male adapter into slide face receiver until it seats. Push down on slider valve assembly to open (Fig. 9).

**Hang power cable, breather tubing with Equalizer, and lifting rope to prevent them from laying in sewage.** Keep between 18 inches and 24 inches of power supply cable in tank. The Equalizer should be hung as high as possible in the tank. Refer to the "Installation Layout" drawing in the front of this manual.

### 13. Test Procedure

Make certain that all discharge shutoff valves are fully open (curb stops, slider valve, etc.). Turn off power at main power supply **and panel**. Use an ohmmeter set at the 2 meg scale. Check the continuity between the following leads from the Upgrade (tests should be performed with the pump and alarm breakers inside the panel OFF):

- Green/yellow to red
- Green/yellow to black
- Green/yellow to brown
- Brown to yellow

All these tests must read an open circuit. A short at any of these test points will cause premature pump failure if not corrected.

Turn on power at main power supply only. Check voltage from the main power supply. The voltage must be 240 VAC (or 120 VAC for a 120V model) within 10 percent. Note the voltage.

Turn on the alarm power circuit breaker. Leave pump breaker off.

Fill tank with water until alarm turns on. This will be about 30 inches from bottom of tank. Turn off water. Turn on pump power circuit breaker. Pump should immediately turn on.

Take a current (amperage) reading off the black lead to the Upgrade. The reading should be between 5 and 8 amps for 240 VAC service (10 to 16 amps for 120 VAC service). Higher amperage readings equal a higher discharge pressure. If the amperage is greater than 8 (16 for 120 VAC service) check the discharge line for a blockage. Note the amperage.

Within the first 1 to 3 minutes, the alarm will turn off. Within the following 1 to 2 minutes, the pump will turn off (in a 24-inch diameter tank).

Close and lock the alarm panel. Inspect the lid gasket and install new gasket material as required. Fasten lid to tank.

Call your local E/One distributor if you experience any problems. Please have ready the unit serial number, voltage, amperage read during startup, type of application, and a description of the problem.

# Grinder Pump Station Ballast Calculations

Any buried vessel that is submerged, or partially submerged, in water will be acted on by an upward buoyant force that attempts to return the vessel to a non-submerged state. The magnitude of this buoyant force is equal to the volume of the vessel that is submerged multiplied by the density of water. On most in-ground installations a ballast, or concrete anchor, of proper volume and weight is required to resist the buoyant force.

The amount of ballast needed is equal to the weight it would take to counterbalance the buoyant forces that are exerted on the station. The total ballast is a combination of the concrete poured to create a ring around the bottom of the station and the soil above that ring which act as a weight. The ballast force, the force holding the station down, must be greater than the buoyant force, the force pushing the station up, in order to have an acceptable installation.

Calculate the Buoyant Force:

STATION VOLUME X THE WEIGHT OF WATER PER CUBIC FOOT (62.4 LBS/CU FT) =  
BUOYANT FORCES

BUOYANT FORCES – STATION WEIGHT =  
NET BUOYANT FORCE

*Example: WH101-92,*  
 $28.53 \text{ cu ft} \times 62.4 \text{ lbs/cu ft} = 1780.3 \text{ lbs}$   
 $1780.3 \text{ lbs} - 270 \text{ lbs} = 1510.3 \text{ lbs}$

Calculate the Ballast Force:

VOLUME OF CONCRETE X WEIGHT OF CONCRETE WATER (87.6 LBS/CU FT) =  
BALLAST FROM CONCRETE

VOLUME OF CONTRIBUTING SOIL X WEIGHT OF SATURATED SOIL (70 LBS/CU FT) =  
BALLAST FROM SOIL

BALLAST FROM CONCRETE + BALLAST FROM SOIL = NET BALLAST FORCE

*Example: WH101-92,*  
 $\text{concrete: } 2.7 \text{ cu ft} \times 87.6 \text{ lbs/cu ft} = 236.5 \text{ lbs}$   
 $\text{soil: } 20.4 \text{ cu ft} \times 70 \text{ lbs.cu ft} = 1430.0 \text{ lbs}$   
 $236.5 \text{ lbs} + 1430.0 \text{ lbs} = 1665.5 \text{ lbs}$

Net Ballast Force @ 1665.5lbs > Net Buoyant Force @ 1510.3 lbs  
Acceptable

Example, WH101-92:  
Station Volume = 28.5 cu ft  
Station Weight = 270 lbs  
Contributing Soil Volume = 20.4 cu ft  
Recommended Concrete Volume = 2.7 cu ft (O.D. = 36")

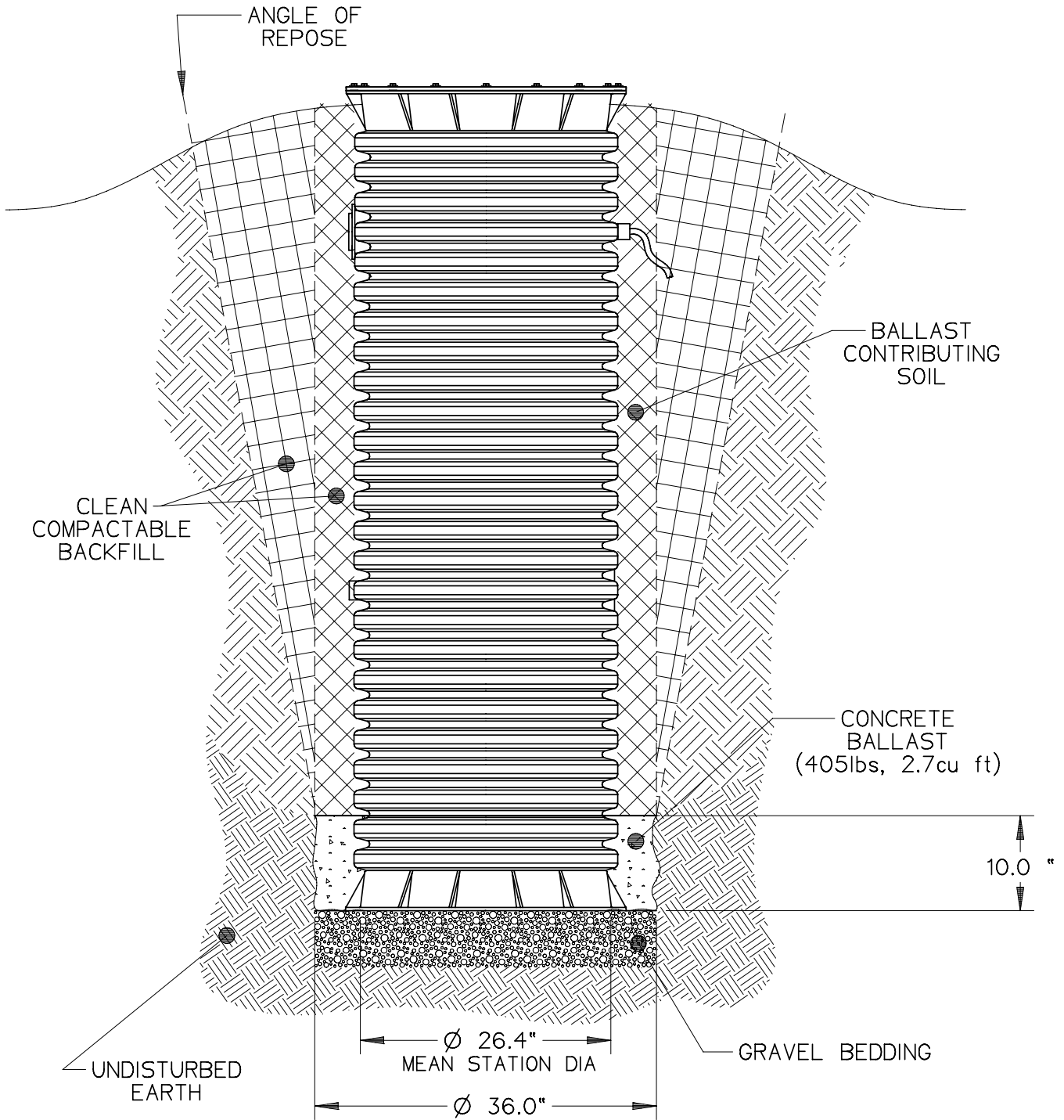

Chart 1

MODEL	MATERIAL	STATION HEIGHT (inches)	STATION WEIGHT (pounds)	STATION VOLUME (cubic feet)	NET BUOYANT FORCE (pounds)	NET BALLAST FORCE (pounds)	CONCRETE VOLUME (cubic feet)	CONCRETE WEIGHT (pounds)
WH101-61	HDPE	60.8	238	19.27	884.45	1108.72	2.7	405
WH101-74	HDPE	73.4	254	23.26	1197.42	1348.82	2.7	405
WH101-92	HDPE	90.1	270	28.53	1510.27	1867.15	2.7	405
WH101-129	HDPE	130.3	280	41.27	2295.25	2433.82	2.7	405
WH101-160	HDPE	158.6	307	50.24	2827.88	2974.22	2.7	405









A Precision Castparts Company

---

Environment One Corporation  
2773 Balltown Road  
Niskayuna, New York 12309-1090

Voice: (01) 518.346.6161  
Fax: 518.346.6188

[www.eone.com](http://www.eone.com)

NA0068P01 Rev A

# User Instructions for the Environment One Grinder Pump

Congratulations on your Environment One grinder pump investment. With proper care and by following a few guidelines, your grinder pump will give you years of dependable service.

## General Information

In order to provide you with suitable wastewater disposal, your home is served by a low pressure sewer system. The key element in this system is an Environment One grinder pump. The tank collects all solid materials and effluent from the house. The solid materials are then ground to a small size suitable for pumping as a slurry with the effluent water. The grinder pump generates sufficient pressure to pump this slurry from your home to the wastewater treatment receiving line and/or disposal plant.

This device complies with Part 15 of the FCC rules. Operation is subject to the following two conditions: 1) this device may not cause harmful interference; and 2) this device must accept any interference received, including interference that may cause undesired operation. Any changes or modifications not expressly approved by the party responsible for compliance could void the user's authority to operate this equipment.

## Care and Use of your Grinder Pump

The Environment One grinder pump is capable of accepting and pumping a wide range of materials. Regulatory agencies advise that the following items should not be introduced into any sewer, either directly or through a kitchen waste disposal unit:

Glass	Seafood shells	Diapers, socks, rags or cloth
Metal	Plastic objects (toys, utensils, etc.)	Kitty litter
Goldfish stone	Sanitary napkins or tampons	

In addition, you must **never** introduce into any sewer:

Explosives	Strong chemicals	Lubricating oil and/or grease
Flammable material	Gasoline	

## Periods of Disuse

If your home or building is left unoccupied for longer than a couple of weeks, perform the following procedure: **Purge the System.** Run clean water into the unit until the pump activates. Immediately turn off the water and allow the grinder pump to run until it shuts off automatically.

**Duplex Units.** Special attention must be taken to ensure that both pumps turn on when clean water is added to the tank.

**Caution: Do not disconnect power to the unit**

## Power Failure

Your grinder pump cannot dispose of wastewater without electrical power. If electrical power service is interrupted, keep water usage to a minimum.

## Pump Failure Alarm

Your Environment One grinder pump has been manufactured to produce an alarm signal (120 volt) in the event of a high water level in the basin. The installer must see that the alarm signal provided is connected to an audible and/or visual alarm in such a manner as to provide adequate warning to the user that service is required. During the interim prior to the arrival of an authorized service technician, water usage must be limited to the reserve capacity of the tank.

**For service, please call your local distributor:**

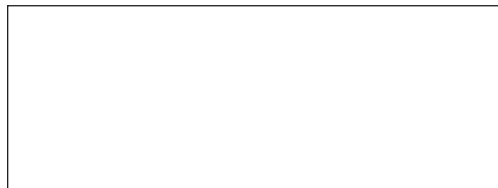

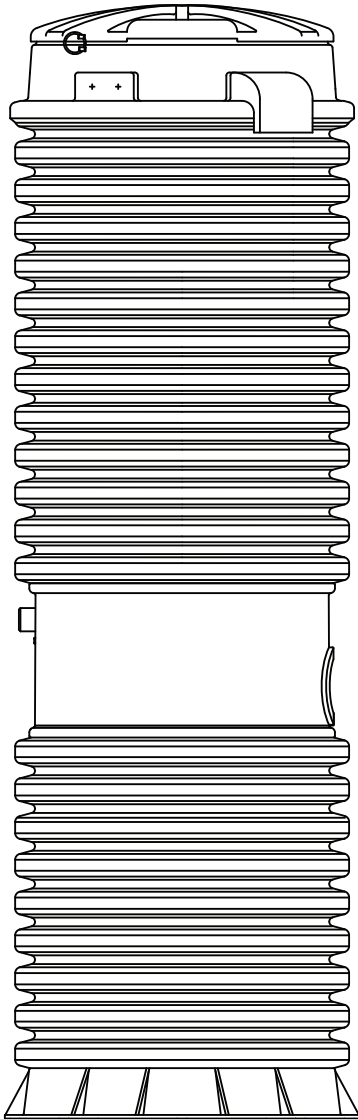

## Limited Warranty

For E/One Extreme D-Series,  
W-Series & Upgrade

Environment One Corporation offers a limited warranty that guarantees its product to be free from defects in material and factory workmanship for a period of two years from the date of installation, or 27 months from the date of shipment, whichever occurs first, provided the product is properly installed, serviced and operated under normal conditions and according to manufacturer's instructions. Repair or parts replacement required as a result of such defect will be made free of charge during this period upon return of the defective parts or equipment to the manufacturer or its nearest authorized service center.

Model Number: \_\_\_\_\_  
Serial Number: \_\_\_\_\_  
Installation Date: \_\_\_\_\_



SEWER SYSTEMS

2773 Balltown Rd • Niskayuna NY USA 12309  
(01) 518.346.6161 • [www.eone.com](http://www.eone.com)