

**WH231 & WR231**  
**SQUAT™**  
**Typical Installation**  
**Instructions**  
**& Warranty**  
**Information**

---

**Simplex Station**  
**230-Gal. Capacity**

# Environment One Grinder Pump Feature Identification

1. **GRINDER PUMP BASIN** – Polyethylene
2. **ACCESSWAY COVER** – High density polyethylene (HDPE)
3. **ELECTRICAL QUICK DISCONNECT (EQD)** – Cable from pump core terminates here.
4. **POWER AND ALARM CABLE** – Circuits to be installed in accordance with local codes.
5. **ALARM PANEL** – NEMA 4X enclosure and equipped with circuit breakers. Locate according to local codes.
6. **ALARM DEVICE** – Every installation is to have an alarm device to alert the homeowner of a potential malfunction. Visual devices should be placed in very conspicuous locations.
7. **INLET** – EPDM grommet (4.5” ID). For 4.5” OD DWV pipe (standard).
8. **WET WELL VENT** – 2.0” tank vent.
9. **GRAVITY SERVICE LINE** – 4” DWV, (4.5 OD). Supplied by others.
- 9a. **STUB-OUT** – 4” X 5’ long **watertight** stub-out, to be installed at time of burial unless the gravity serviceline is connected during installation. Supplied by others.
10. **DISCHARGE FTG** – 1-1/4” Female NPT, stainless steel.
11. **DISCHARGE LINE** – 1-1/4” Nominal pipe size. Supplied by others.
12. **CONCRETE ANCHOR** – See Ballast Calculations for specific weight for your station height. Supplied by others.
13. **BEDDING MATERIAL** – 6” minimum depth, round aggregate, (gravel). Supplied by others.
14. **FINISHED GRADE** – Grade line to be 1” to 2” below removable lid and slope away from the station.
15. **CONDUIT** – 1” or 1-1/4”, material and burial depth as required per national and local codes. Conduit must enter panel from bottom and be sealed per NEC section 300.5 & 300.7. Supplied by others.
16. **REBAR** – For use with precast concrete ballast. Required to lift tank after ballast (concrete anchor) has been attached, 4 places, evenly spaced around tank.

Figure 1a

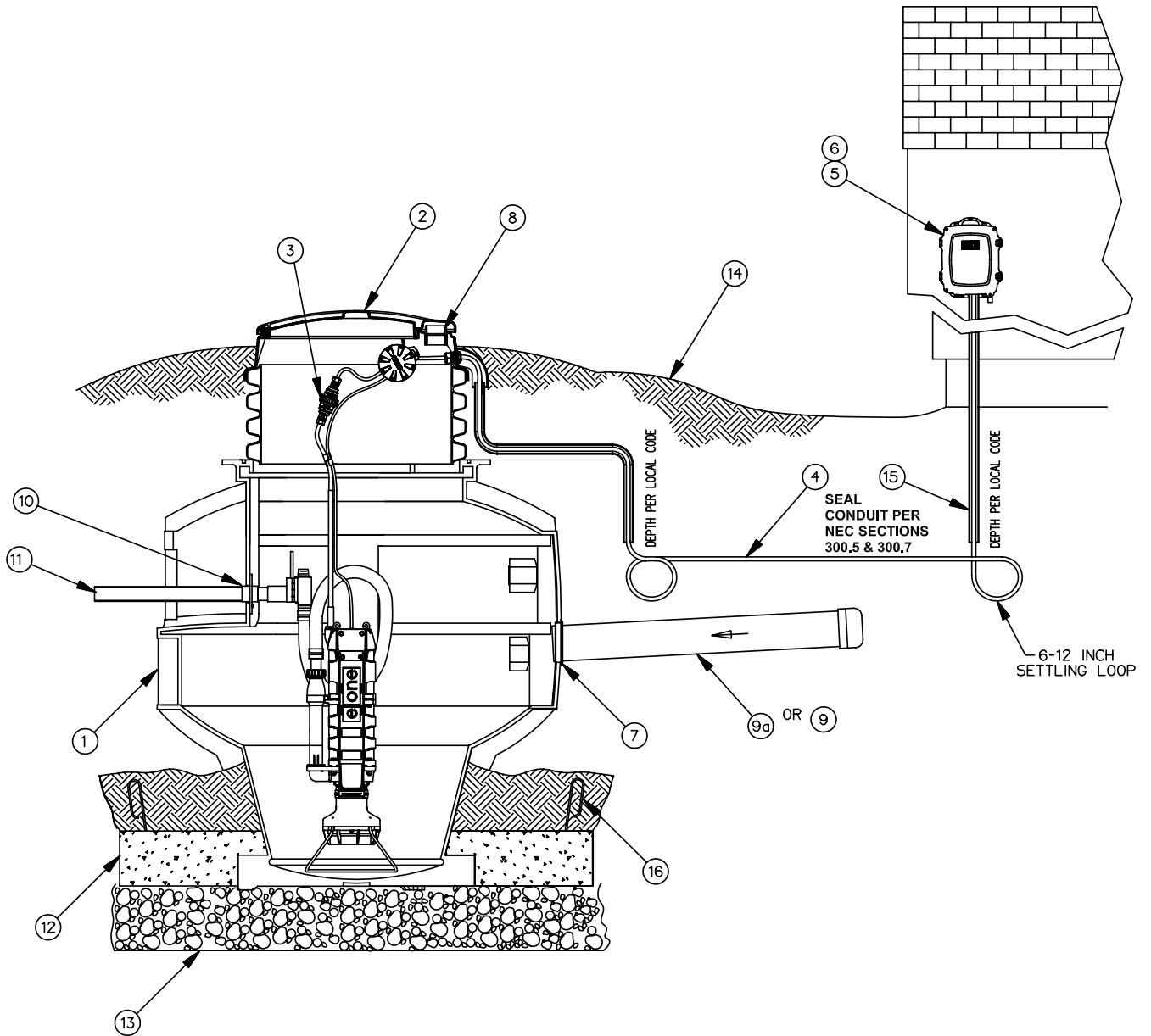

**FAILURE TO COMPLY  
WITH INSTALLATION  
INSTRUCTIONS WILL  
VOID WARRANTY**

The following instructions define the recommended procedure for installing the Model WH/WR231 grinder pump station.

This is a sewage handling pump and must be vented in accordance with local plumbing codes. This pump is not to be installed in locations classified as hazardous in accordance with National Electric Code, ANSI / NFPA 70. All piping and electrical systems must be in compliance with applicable local and state codes.

**1. REMOVE PACKING MATERIAL:**

The User Instructions must be given to the homeowner. Hardware supplied with the unit, if any, will be used at installation.

**2. TANK INSTALLATION:**

The tank is typically supplied with a standard grommet for connecting the 4" DWV (4.50" outside dia.) incoming sewer drain. Other inlet types and sizes are optional. CAUTION: 4" DR-35 pipe has a smaller diameter and won't create a watertight joint with the standard grommet. Confirm that you have the correct inlet before continuing. If a concrete ballast is attached to the tank, lift only by the lifting eyes (rebar) embedded in the concrete. **Do not drop, roll, or lay tank on its side. This will damage the unit and void the warranty.**

Excavate a hole to a depth so that the station cover extends 1" to 2" above the finished grade line. The finished grade must slope away from the station cover to prevent surface water from entering the station. The diameter of the hole shall be large enough to allow for the concrete ballast

anchor. The size, shape and shoring requirements of the excavation will be based on the soil conditions and must be in accordance with the site engineer's recommendation and safety requirements. Care must be taken during lifting and placement to prevent impacting or otherwise damaging the tank (see Lifting Instructions). Only a non-marring sling, rated for the load being lifted, should be used in contact with the tank surfaces. Lifting chains or cables should not be placed in direct contact with the tank surfaces.

Place the station on a bed of gravel, naturally rounded aggregate, clean and free

flowing, with particles not less than 1/8" or more than 3/4" in size.

A concrete ballast anchor is required to prevent flotation of the tank when groundwater is present. The concrete anchor is not optional. The MINIMUM concrete anchor requirements for the WH/WR231 station are shown in Chart 1 of the Ballast Calculation section. Ensure the tank is properly positioned in the excavation to support inlet pipe (Section 3) and discharge pipe (Section 5) connections before pouring the concrete ballast. The unit should be leveled and filled with water to approximately the bottom of the inlet pipe to prevent shifting

Figure 2a

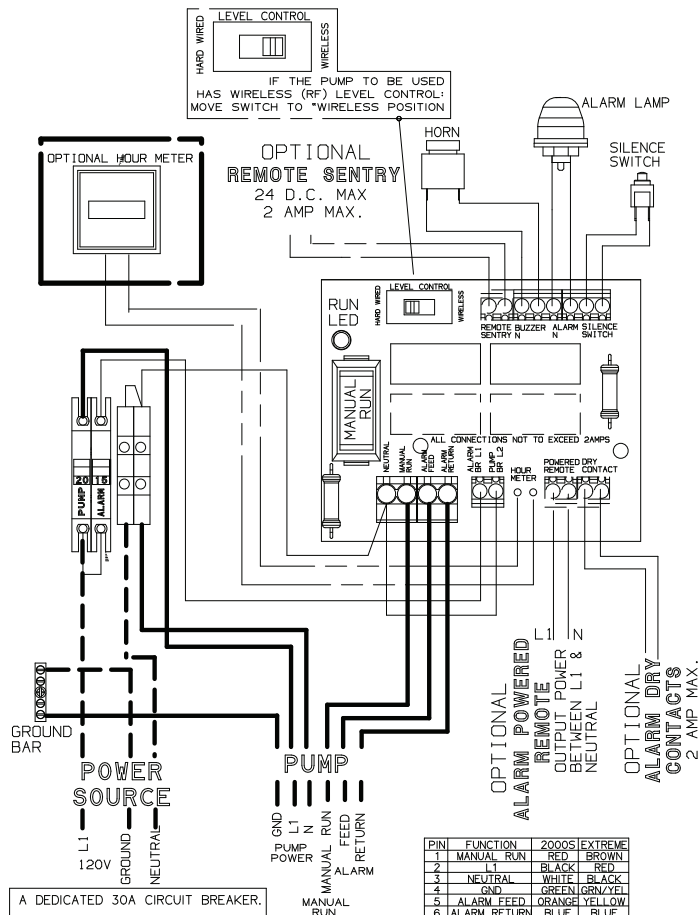

**120 VOLT WIRING**

while the ballast is being poured. The concrete should be vibrated, as necessary, to eliminate voids. If it is necessary to pour the concrete above the inlet level (Section 3), the inlet must be sleeved with an 8" tube before pouring.

Concrete ballast should be cast in-place around the tank in the excavation (Figure 3). Alternatively, pre-cast ballast around the base of the tank may be used. If the concrete is pre-cast, lifting hooks must be anchored in the ballast to support subsequent handling of the tank (see Lifting Instructions). The lifting hooks used must be adequate to support the combined weight of

the tank and concrete ballast and shall be sized and installed in accordance with the site engineer's recommendation.

**Place the ballasted tank on the gravel bedding in the excavated hole using the lifting hooks. Do not lift by any of the tank surfaces if pre-cast ballast is utilized.**

### 3. INLET LOCATIONS:

A 4" (standard) DWV inlet grommet was provided with the station for sealing the inlet pipe at the tank wall. If the inlet grommet penetration was not factory installed, the location of the tank inlet must be determined to support final positioning of the tank prior to ballast installation (see Section

2). The inlet pipe location corresponds with the actual or projected point where the 4" building sewer line intersects the tank wall. The grade of the inlet pipe and required burial depth (per national and local code requirements) must be accounted for when determining the inlet location. The supply cable path should be considered when selecting the inlet location (see Section 8). A 5" diameter field penetration of the tank wall is required to support installation of the (standard) inlet grommet. This penetration must not remove or interfere with any of the structural ribbing on the polyethylene tank. The inlet grommet may be installed in any of the allowable locations shown in Figure 6. The inlet penetration **must** be centered in the location selected to prevent interference with the tank ribbing. Typical inlet installation will be on one of the three, 6.5" wide, raised panels on the tank body. The panels have been marked with a series of locating lines to support centering of the 5" (standard) drilled penetration. The center of the 4" inlet location must not be located below the recommended minimum inlet center line on the raised panels (Figure 6). Any inlet installed in the depressed panels between the horizontal and vertical ribbing must be centered within the panel to provide adequate clearance for the 6" diameter flange on the standard 4" inlet grommet (Figure 6). Once the location of the inlet penetration is selected, mark the inlet center location on the tank and position the tank. Using

Figure 2b

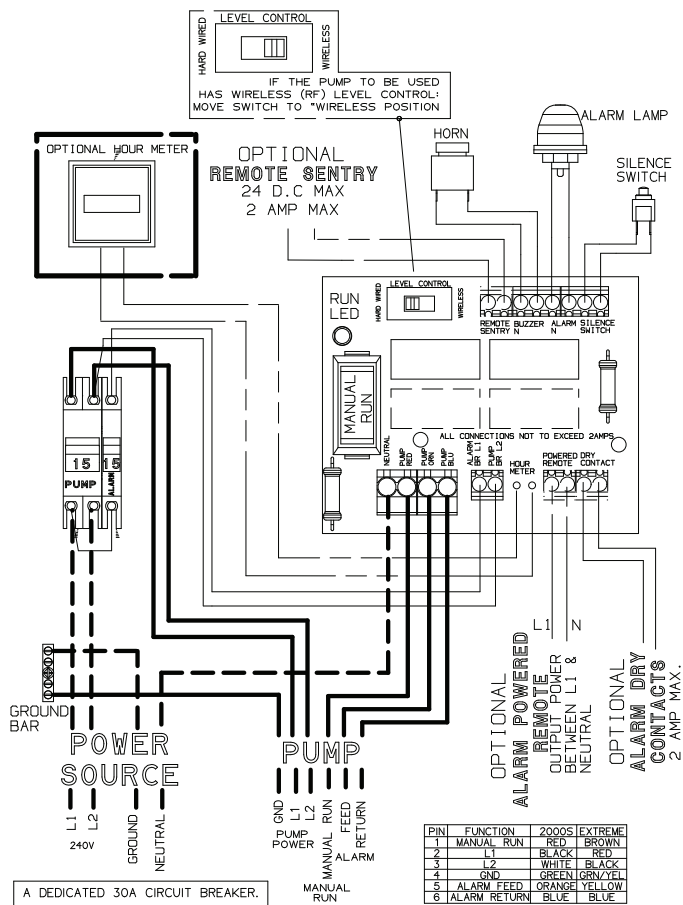

## 240 VOLT WIRING

a 5" diameter hole saw for the standard 4" grommet, drill through the tank wall at the marked location. Remove any chips or burrs from the drilled hole. Install the provided inlet grommet into the drilled hole. The grommet is self-sealing and does not require the use of additional sealant or adhesive.

**4. INLET PIPE**

**INSTALLATION:** Mark the inlet pipe 3 1/2" from the end to be inserted. Inlet pipe should be chamfered and lubricated with a soap solution. Lubricate the inlet grommet with soap solution as well. Insert the pipe into the grommet up to the 3.5" mark. Inspect to ensure the grommet has remained intact and in place (Figure 6).

**5. DISCHARGE:** The use of 1.25" PVC pressure pipe SCH 40 and polyethylene pipe SDR 11 or SIDR 7 are recommended. If polyethylene is chosen, use compression-type fittings to provide a smooth inner passage. It is recommended that a Redundant Check Valve Assembly (E/One part no. PC0051GXX) be installed between the pump discharge and the street main on all installations. Never use a ball-type valve as a check valve. E/One recommends the valve be installed as close to the public right-of-way as possible. Check local codes for applicable requirements.

**CAUTION:** Redundant check valves on station laterals and anti-siphon/check valve assemblies on grinder pump cores should not be used as system isolation valves during line tests.

There is a slide face valve and a quick disconnect

pre-installed in the tank for pump connection. There is a 1.25" NPT female discharge connection on the outside of the tank to support discharge pipe connection.

**6. BACKFILL**

**REQUIREMENTS:** Proper backfill is essential to the long term reliability of any underground structure. Several methods of backfill are available to produce favorable results with different native soil conditions.

The recommended method of backfilling is to surround the unit to grade using Class I or Class II backfill material as defined in ASTM 2321. Class 1A and Class 1B are recommended where frost heave is a concern; Class 1B is a better choice when the native soil is sand or if a high, fluctuating water table is expected. Class I, angular crushed stone, offers an added benefit in that it needs minimal compaction. Class II, naturally rounded stone, may require more compactive effort, or tamping, to achieve the proper

density.

If the native soil condition consists of clean, compactible soil with less than 12% fines, free of ice, rocks, roots, and organic material, it may be an acceptable backfill. Such soil must be compacted in lifts not to exceed one foot to reach a final Proctor Density between 85% and 90%. Non-compactible clays and silts are **not** suitable backfill for this or any underground structure such as inlet or discharge lines. If you are unsure of the consistency of the native soil, it is recommended that a geotechnical evaluation of the material be obtained before specifying backfill.

Another option is the use of a flowable fill (i.e., low slump concrete). This is particularly attractive when installing grinder pump stations in augured holes where tight clearances make it difficult to assure proper backfilling and compaction with dry materials. Flowable fills should not be dropped with more than 4 feet between the discharge

Figure 3

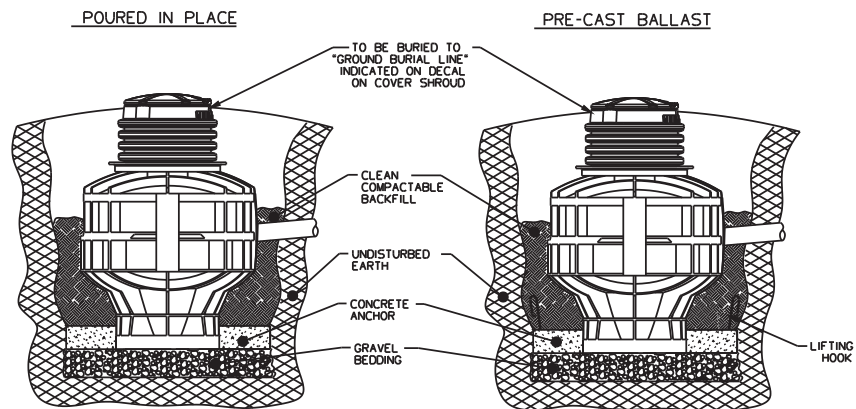

**TYPICAL IN-GROUND SECTION VIEW**

nozzle and the bottom of the hole because this can cause separation of the constituent materials.

**7. VENTING:** The unit must be properly vented to assure correct operation of the pump.

The units are supplied with a 2" vent opening in the cover assembly. Failure to *properly vent* the tank will result in faulty operation and will void the warranty.

If the water level outside of the station is expected to rise above the surrounding grade (flooding), a cover vent system cannot be used. If flood conditions are expected, an underground (lateral) vent system and solid cover must be used. **Consult the factory if flood conditions are possible where the station will be installed.**

**8. ELECTRICAL CONNECTION: (Supply panel to E/One alarm panel)**

Before proceeding, verify that the service voltage is the same as the motor voltage shown on the name plate. An alarm device is to be installed in a

conspicuous location where it can be readily seen by the homeowner. An alarm device is required on every installation. There shall be no exceptions.

Wiring of supply panel and alarm panel shall be per Figures 2a and 2b, alarm panel wiring diagrams and local codes.

**9. ELECTRICAL CONNECTION: (Pump to Panel) (Fig. 4)** The grinder pump station is provided with a cable for connection between the station and the alarm panel (supply cable). The supply cable, a six conductor tray cable, meets NEC requirements for direct burial as long as a minimum of 24" burial depth is maintained. Those portions of the cable which have less than 24" of cover must be contained in suitable conduit. This includes the vertical portion dropping to a 24" depth at the station and the length rising out of the ground at the control panel.

*NOTE: Wiring must be installed per national and local codes. Conduit must enter panel from*

*bottom and be sealed per NEC section 300.5 & 300.7.*

**9a. Installing E/One supply cable:**

1) Open the lid of the station and locate the cable and the feed-through connector on the wall of the shroud or on the inside of the tank wall (Model WH/WR231 x 55"). Loosen the nut on the connector and pull the supply cable out through the connector until it hits the crimped on stop feature on the cable, approximately 36" from the EQD. **\*\*IMPORTANT: All but 36" of the cable must be pulled out of the station, and the EQD and Equalizer should be hung as high in the station as possible to ensure that the pump functions properly. Do not leave the excess cable in the station.**

2) Retighten the nut. This connection must be tight or ground water will enter the station.

3) Feed the wire through the length of conduit (contractor provided), which will protect it until it is below the 24" burial depth.

4) On models WH/WR231 x 73" and taller, position the conduit vertically below the cable connector along side of the station reaching down into the burial depth. Attach the small protective shroud provided with the station to protect the exposed cable where it enters the station. Four self-tapping screws are provided.

5) Run the cable underground, in a trench or tunnel, to the location of the E/One panel. Leave a 6" to 12" loop of cable at each end to allow for shifting and settling. Connections made at the panel

Figure 4

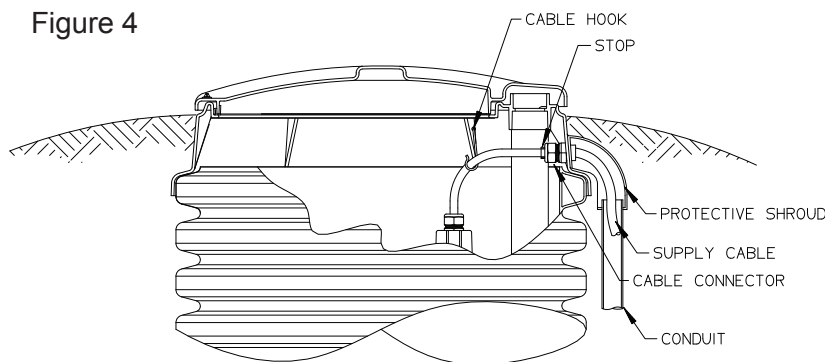

Power at the station must not drop below 10% of nameplate voltage. Maximum Recommended Length:  
 120 Volt 60' (min. voltage at pump — 108V)  
 240 Volt 150' (min. voltage at pump — 216V)  
 Consult factory for longer lengths

**TYPICAL SUPPLY CABLE CONFIGURATION**

Figure 5

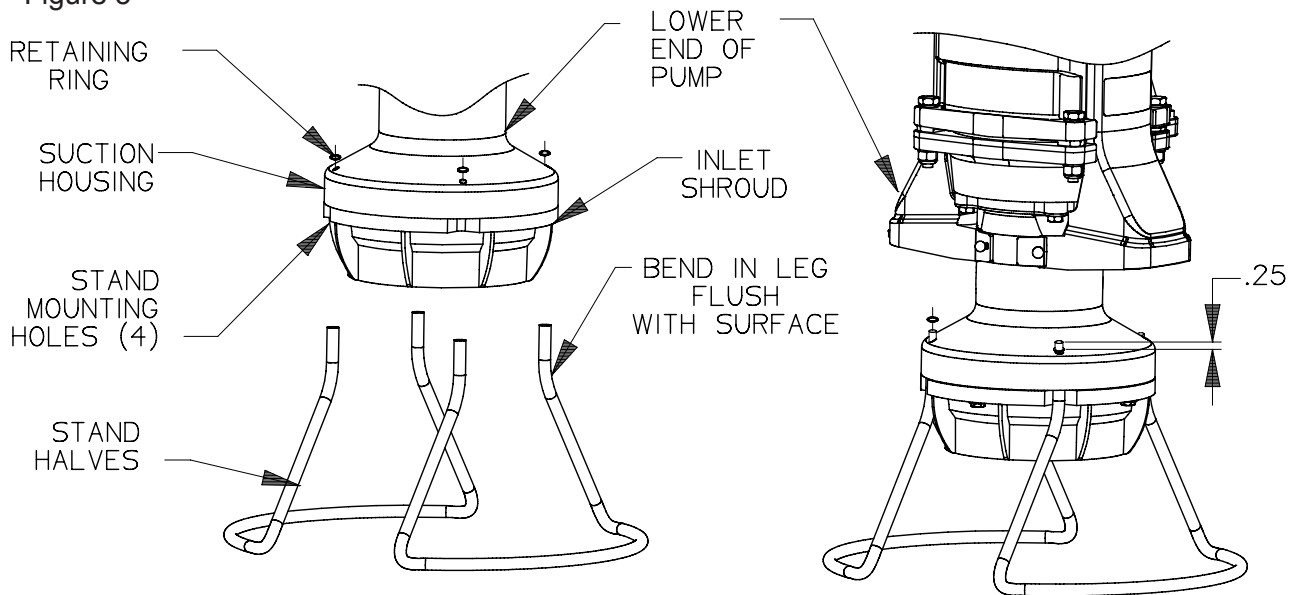

## GRINDER PUMP STAND

are shown in the panel wiring diagram (Figures 2a and 2b).

### 10. GRINDER PUMP STAND ASSEMBLY:

Temporarily rest the grinder pump on its side. Using a block of wood or similar object, prop up the lower pump end to allow installation of the pump stand. Align the two legs of each pump stand half with two of the holes in the pump lower end (Figure 5). Push the stand legs into the pump lower end. Using a mallet, ensure that the stand legs bottom into the mounting holes. Repeat for the other stand half. Turn the pump upright on the installed stand.

### 11. DEBRIS REMOVAL:

The incoming sewer line must be flushed to force all miscellaneous debris into the tank. Next, all liquid and debris must be removed from the tank. Once the tank is clean, install the pump.

### 12. INSTALL THE PUMP:

Lower the pump into the tank. Position the pump so the pump's discharge is on

the opposite side of the pump relative to the discharge in the tank. Position the pump in the center of the tank. Rotate to coil the discharge hose and slide the adapter on the discharge hose into the receiver in the tank wall. Push the white slider down to open the discharge valve. See Figures 7 through 10 for slideface connection and operation.

Hang power cable, breather tubing with Equalizer, and lifting rope to prevent them from laying in sewage. Hang the Equalizer as high as possible in the tank.

### 13. TEST PROCEDURE:

The following test must be performed prior to placing the system in service:

a) Make sure that the discharge slide face valve in the tank is in the open position.

Also, make sure that any additional discharge line valves are open. (Some installations may have additional discharge line valves

before entering the street main.)

b) Fill the tank with approximately 80 gallons of water. This is approximately 28 inches from the bottom (2 to 3 inches below the top of the pump). Shut off the water.

c) Turn "ON" power to the alarm panel, from the building service panel.

d) Set both the alarm circuit breaker and the pump circuit breaker in the alarm panel to the "ON" position. The grinder pump and alarm should turn on immediately.

e) Monitor the pump and alarm to ensure they are operating correctly. The alarm will shut off at a water level of approximately 18" from the bottom. The grinder pump will shut off at a water level of approximately 14" from the tank bottom.

Figure 6

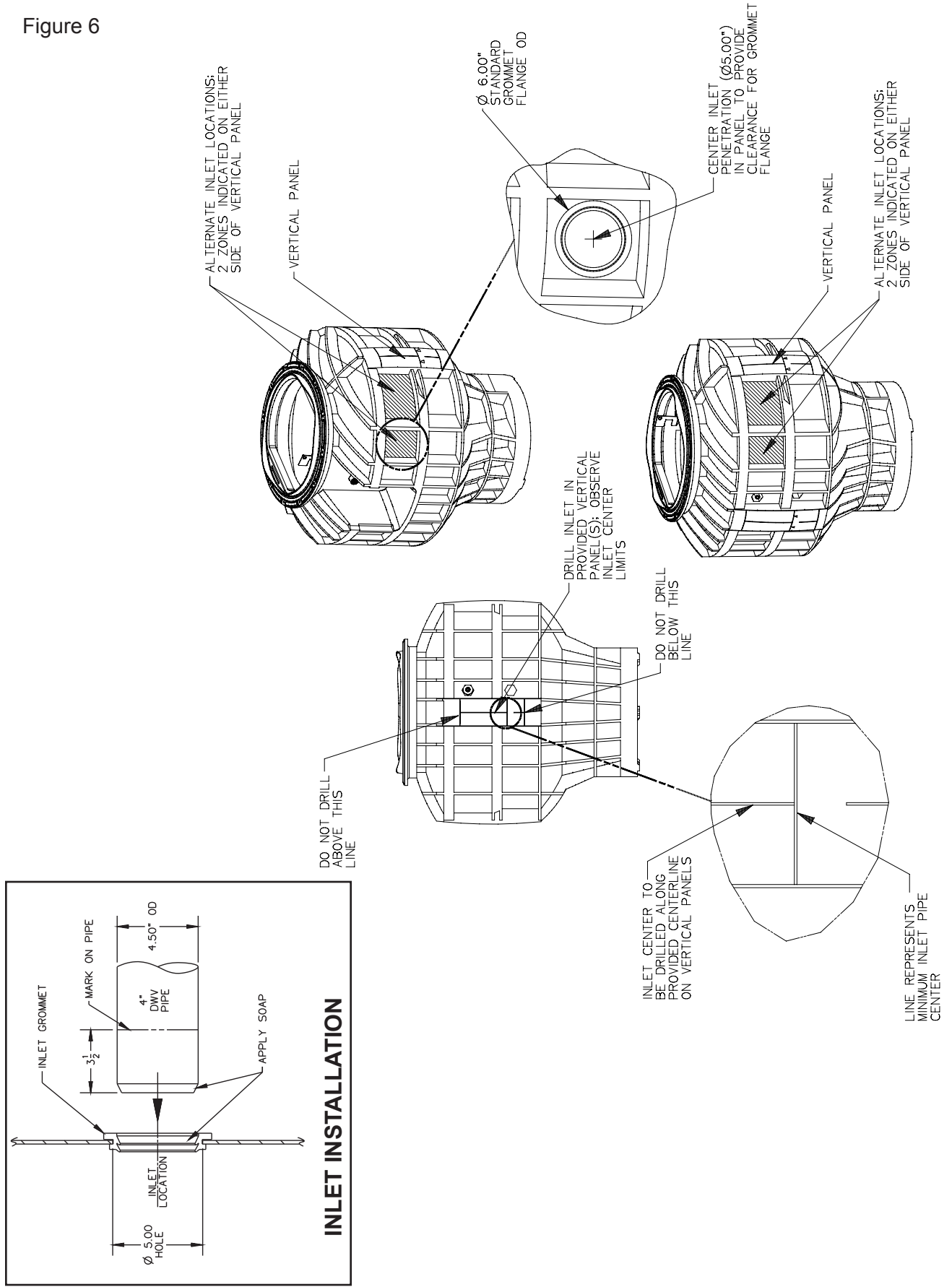

**ALLOWABLE INLET LOCATIONS**

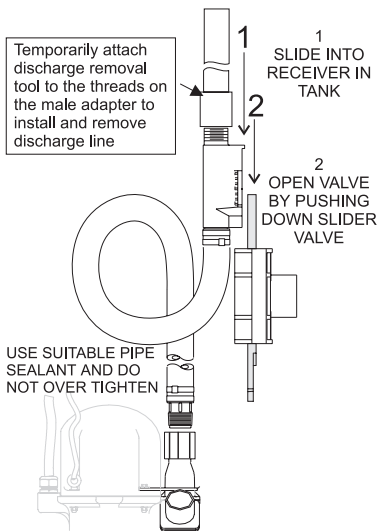

Figure 7

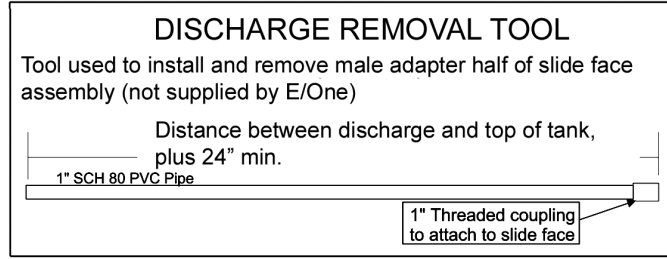

Figure 8

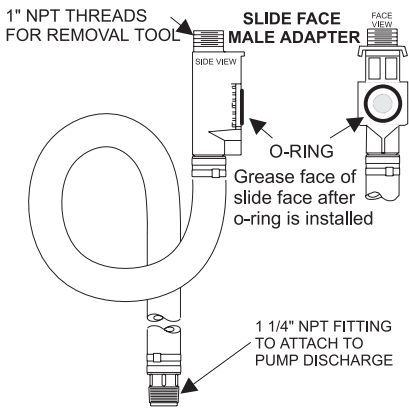

Figure 9

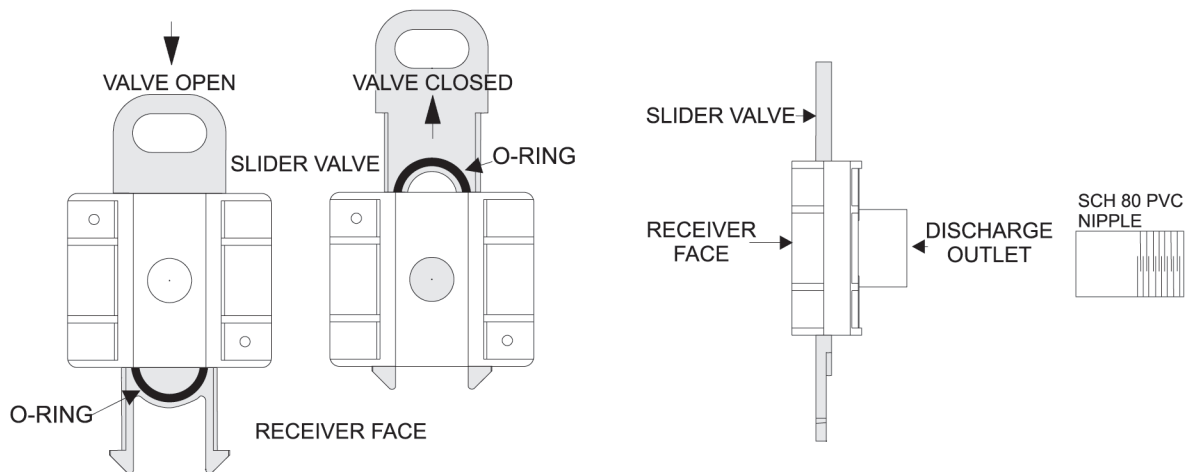

Figure 10

# Lifting Instructions

FAILURE TO FOLLOW THESE INSTRUCTIONS COMPLETELY WILL VOID WARRANTY.

1. Transporting unit to installation site: **Always lift a unit from the bottom for the purpose of transportation. The station should be received attached to a pallet for this purpose.** Never roll a station or move it on its side.

2. No Ballast (to be poured in place): If the concrete anchor is to be poured while the station is in place lift the unit using 2 nylon straps wrapped under the tank flange to make a sling, as shown below. Keep station oriented vertically to avoid any damage.

3. Precast Ballast: Never lift a station that has a ballast attached by any means except the rebar. The weight of the concrete will damage the station if you attempt to lift it from any part of the station.

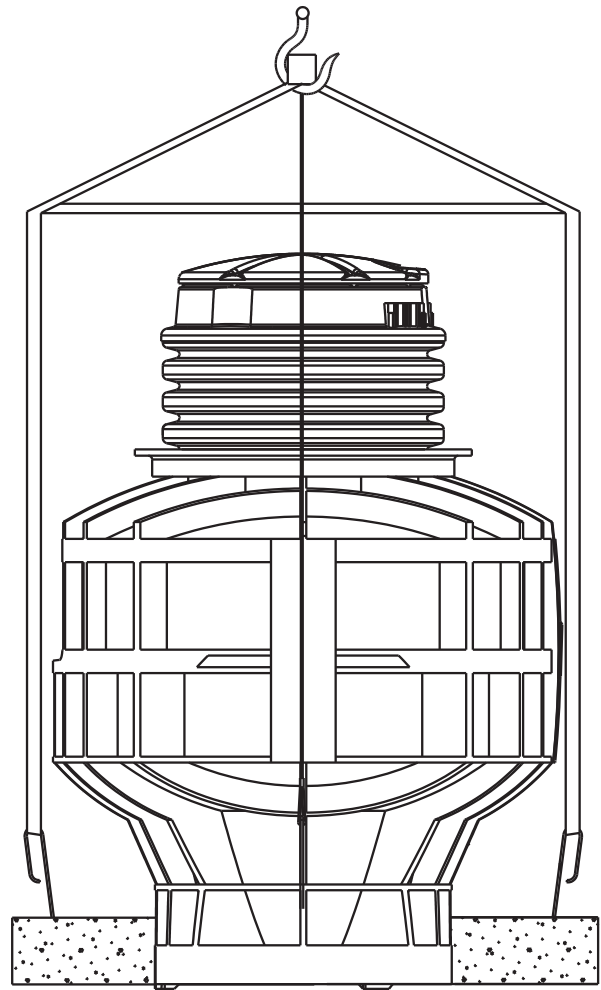
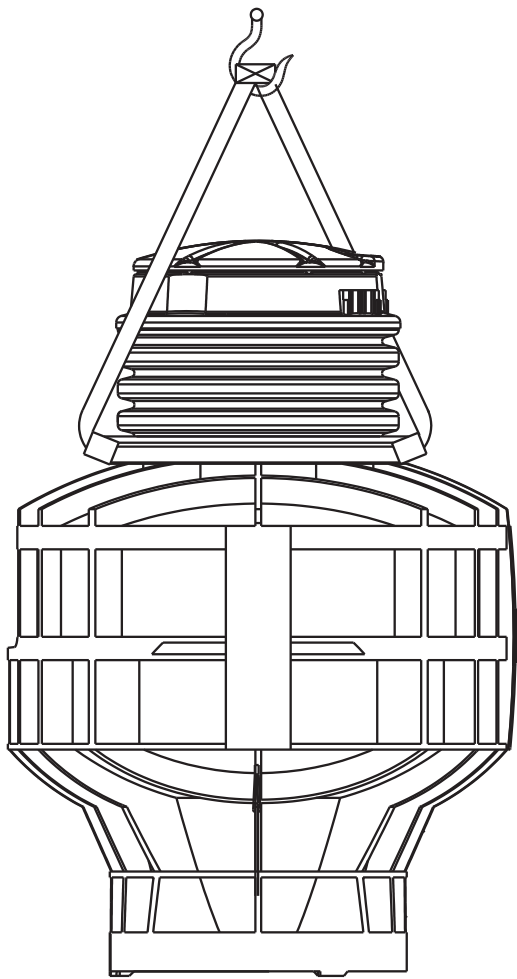

# **E/One Grinder Pump Station Ballast Calculations**

Any buried vessel that is submerged, or partially submerged, in water will be acted on by an upward buoyant force that attempts to return the vessel to a non-submerged state. The magnitude of this buoyant force is equal to the volume of the vessel that is submerged multiplied by the density of water. On most in-ground installations a ballast, or concrete anchor, of proper volume and weight is required to resist the buoyant force. The amount of ballast required for a given set of installation site conditions may be calculated as follows.

## **Installation Site Assumptions**

1. Water table – under worst case, the ground water level is assumed to be at the finished-grade level.
2. Backfill materials are per E/One Installation Instructions.
3. The consulting engineer should perform a soil test to determine if the assumptions that have been made are valid. If the site conditions differ from these assumptions, then the consulting engineer must revise the calculations as shown in this document.

## **Physical Constants**

1. Density of Water = 62.4 lb/cu ft
2. Density of Concrete = 150 lb/cu ft (in air)
3. Density of Concrete = 87.6 lb/cu ft (in water)
4. Density of Dry Compacted Backfill = 110 lb/cu ft
5. Density of Saturated Backfill = 70 lb/cu ft

## **Procedure**

### **A. Determine The Buoyant Force Exerted On The Station**

1. Determine the buoyant force that acts on the grinder pump station when it is submerged in water.
2. Subtract the weight of the station from the buoyant force due to the submerged tank to determine the net buoyant force acting on the station.

### **B. Determine The Ballast Force Exerted On The Station**

1. Determine the ballast force applied to the station from the concrete, saturated soil and dry soil.

### **C. Subtract The Ballast Force From the Buoyant Force.**

1. Note – if the installation site conditions are different from those listed above, the consulting engineer should recalculate the concrete ballast.

## **Ballast Calculations**

The following calculations are to outline the areas used to determine the volumes of the different materials for the ballast. All sections referred to in the calculations are marked on the accompanying drawing.

# E/One Grinder Pump Station Ballast Calculations

## Sample Calculation — Station Height of 55”

Volume of Station Wet Well = 36.4 cu ft

Station Weight = 213 lbs

Station Height = 4.6 ft

### A. Buoyant Force

1. The buoyant force acting on the submerged WH231 is equal to the weight of the displaced water for the section of the tank that is submerged.

$$\begin{aligned}F_{\text{buoyant}} &= (\text{density of water})(\text{volume of station}) \\ &= (62.4 \text{ lbs/cu ft})(36.4 \text{ cu ft}) \\ &= 2271 \text{ lbs}\end{aligned}$$

2. The net buoyant force acting on the station ( $F_{\text{net-buoyant}}$ ) is equal to the buoyant force ( $F_{\text{buoyant}}$ ) minus the weight of the station tank.

$$\begin{aligned}F_{\text{net-buoyant}} &= 2271 \text{ lbs} - 213 \text{ lbs} \\ &= 2058 \text{ lbs}\end{aligned}$$

### B. Ballast Force

1. Determine the volume of concrete and soil

Section I: Used To Determine The Volume Of Concrete

(Note: 2.50 ft = assumed inside diameter of concrete ballast ring around tank's bottom flange)

$$\begin{aligned}\text{Volume} &= (\text{Height})(\text{Area}) \\ &= (.58 \text{ ft})(\pi)((5.0 \text{ ft})^2 - (2.5 \text{ ft})^2) / 4 \\ &= (.58 \text{ ft})(14.74 \text{ ft}^2) \\ &= 8.58 \text{ ft}^3\end{aligned}$$

Section II: Used To Determine The Volume Of Saturated Soil

(Note: 4.26 ft = assumed inside diameter of soil column around tank's maximum diameter)

$$\begin{aligned}\text{Volume} &= (\text{Height})(\text{Area}) \\ &= (4.6 \text{ ft} - .58 \text{ ft})(\pi)((5.0 \text{ ft})^2 - (4.26 \text{ ft})^2) / 4 \\ &= (4.02 \text{ ft})(5.35 \text{ ft}^2) \\ &= 21.63 \text{ ft}^3\end{aligned}$$

2. Determine the combined ballast

$$\begin{aligned}\text{Ballast (total)} &= \text{Ballast (concrete)} + \text{Ballast (saturated soil)} \\ &= (V_{\text{concrete}})(\text{density concrete in water}) + (V_{\text{soil}})(\text{density saturated soil}) \\ &= (8.53 \text{ ft}^3)(87.52 \text{ lbs/ft}^3) + (21.63 \text{ ft}^3)(70 \text{ lbs/ft}^3) \\ &= 750 \text{ lbs} + 1514 \text{ lbs} \\ &= 2264 \text{ lbs}\end{aligned}$$

- C. Subtract the buoyant force from the ballast force to determine the final condition

$$\begin{aligned}\text{Final Condition} &= \text{Ballast Force} - \text{Net Buoyant Force} \\ &= 2264 \text{ lbs} - 2058 \text{ lbs} \\ &= 206 \text{ lbs (excess ballast)}\end{aligned}$$

# E/One Grinder Pump Station Ballast Calculations

## Sample Calculation

The approach outlined on the previous page may be used to calculate the ballast requirements listed below.

Chart 1

Station Height (in.)	Station Volume (cu ft)	FNet Buoyant (lbs)	Tank Weight (lbs)	FBallast (lbs)	Volume Concrete (cu ft)*	Weight Concrete in Air (lbs)*	Minimum Diameter of Concrete Anchor (in.)	Minimum Thickness of Concrete Anchor (in.)
55 inches	36.4	2058	213	2264	8.58	1287	60	7
73 inches	40.5	2302	225	2815	8.58	1287	60	7
92 inches	44.6	2546	237	3416	8.58	1287	60	7

\* Volume calculated is for minimum dimensions given. Minimum dimensions must be met or exceeded for actual application.

E/ONE  
RECOMMENDED  
BACKFILL

SOIL  
CONSIDERED  
DISTRIBUTING  
TO BALLAST

UNDISTURBED  
EARTH

CONCRETE  
BALLAST  
ANCHOR

GRAVEL  
BEDDING

7.0"  
MINIMUM  
THICKNESS

Ø29.9"

Ø60.0"  
MINIMUM  
BALLAST

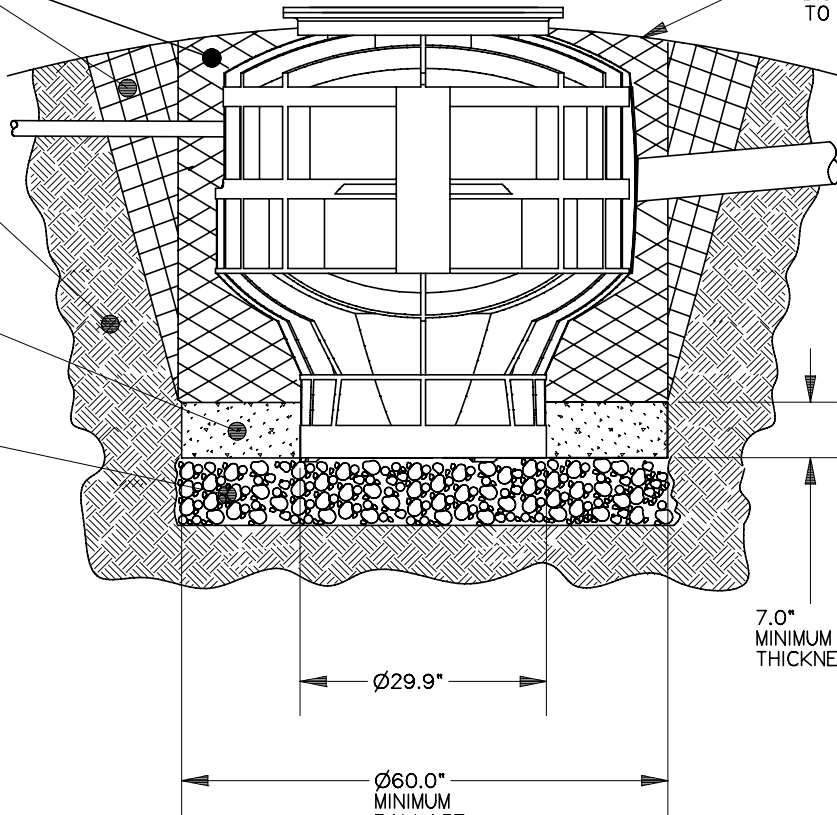

AD	CAH	04/21/06	-	1/16
DR BY	CHK'D	DATE	ISSUE	SCALE
				
BALLAST INFORMATION				

# Adjusting the Height of a Grinder Pump Station

## TO INCREASE STATION HEIGHT 6 INCHES (73" TO 92" STATIONS ONLY)

1. Increasing station height can be done without cutting the station. Use the E/One Extender cover shroud kit (ND0082G01) and follow the instructions that are included with the kit.

## TO REDUCE THE STATION HEIGHT:

### REMOVE EXISTING COVER ASSEMBLY (Fig. 11)

If your existing station has a welded-on cover shroud, you will need the appropriate replacement cover kit.

1. Turn off all power to the grinder pump station.
2. Remove the tank lid and the electrical shroud.
3. Unplug the electrical quick disconnect (EQD) and remove the EQD from the supply cable. *Note: DO NOT CUT CABLE.* Loosen liquid-tight cable connector and pull the supply cable out through the connector on the side of tank.
4. Remove the soil around the tank, exposing three of the tank corrugations below grade. Use caution not to damage buried cable.
5. Remove existing cover shroud.

5a. Welded-on shroud (standard) — Using a hand saw, cut the tank in the valley between the two corrugations at grade, discard existing welded on shroud and attached corrugations (*shroud is not to be reused*). *Caution: Be careful not to cut the pump breather cable.*

5b. Clamped-on shroud — Remove band clamp and cover shroud.

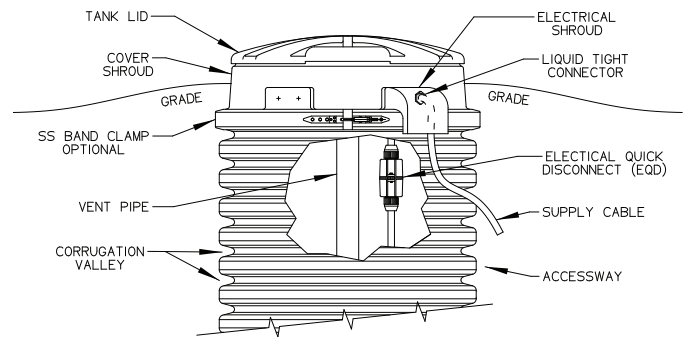

Figure 11

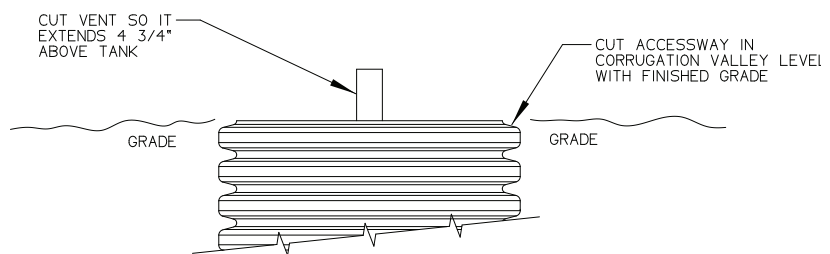

Figure 12

### REDUCING STATION HEIGHT (Fig. 12)

6. Using a hand saw, cut the tank in the valley between the two corrugations at grade.

### INSTALL REPLACEMENT COVER ASSEMBLY (Fig. 13)

7. Clean top corrugation on accessway extension and mating surface of replacement shroud with acetone.

8. Liberally apply the silicone sealer provided to the under side of the replacement shroud where it will come in contact with the accessway extension.

9. Place SS band clamp around top corrugation and the replacement shroud. Tap with a mallet around clamp to help seat the clamp. Torque stud assembly on band clamp to a maximum 125 inlb.

10. Reinstall the supply cable, EQD, tank lid and electrical shroud and tighten cable connector.

11. Follow start-up procedures to ensure proper pump operation (you will find the start-up instructions in the service manual).

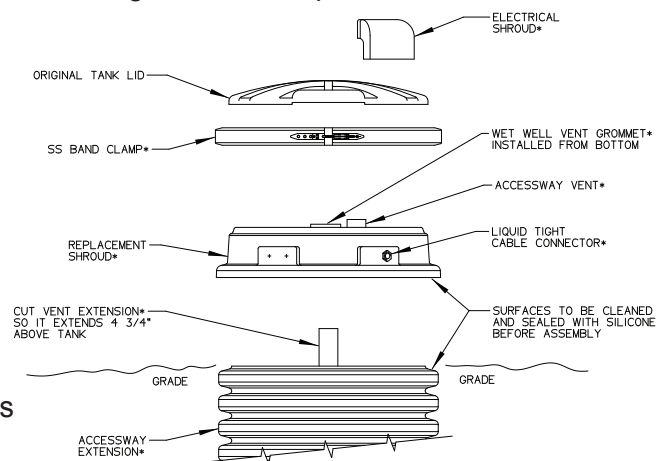

Figure 13





*A Precision Castparts Company*

---

Environment One Corporation  
2773 Balltown Road  
Niskayuna, New York 12309-1090

Voice: (01) 518.346.6161  
Fax: 518.346.6188

[www.eone.com](http://www.eone.com)

NA0069P01 Rev C  
3/12

# User Instructions for the Environment One Grinder Pump

Congratulations on your Environment One grinder pump investment. With proper care and by following a few guidelines, your grinder pump will give you years of dependable service.

## General Information

In order to provide you with suitable wastewater disposal, your home is served by a low pressure sewer system. The key element in this system is an Environment One grinder pump. The tank collects all solid materials and effluent from the house. The solid materials are then ground to a small size suitable for pumping as a slurry with the effluent water. The grinder pump generates sufficient pressure to pump this slurry from your home to the wastewater treatment receiving line and/or disposal plant.

This device complies with Part 15 of the FCC rules. Operation is subject to the following two conditions: 1) this device may not cause harmful interference; and 2) this device must accept any interference received, including interference that may cause undesired operation. Any changes or modifications not expressly approved by the party responsible for compliance could void the user's authority to operate this equipment.

## Care and Use of your Grinder Pump

The Environment One grinder pump is capable of accepting and pumping a wide range of materials. Regulatory agencies advise that the following items should not be introduced into any sewer, either directly or through a kitchen waste disposal unit:

Glass	Seafood shells	Diapers, socks, rags or cloth
Metal	Plastic objects (toys, utensils, etc.)	Kitty litter
Goldfish stone	Sanitary napkins or tampons	

In addition, you must **never** introduce into any sewer:

Explosives	Strong chemicals	Lubricating oil and/or grease
Flammable material	Gasoline	

## Periods of Disuse

If your home or building is left unoccupied for longer than a couple of weeks, perform the following procedure:

**Purge the System.** Run clean water into the unit until the pump activates. Immediately turn off the water and allow the grinder pump to run until it shuts off automatically.

**Duplex Units.** Special attention must be taken to ensure that both pumps turn on when clean water is added to the tank.

**Caution: Do not disconnect power to the unit**

## Power Failure

Your grinder pump cannot dispose of wastewater without electrical power. If electrical power service is interrupted, keep water usage to a minimum.

## Pump Failure Alarm

Your Environment One grinder pump has been manufactured to produce an alarm signal (120 volt) in the event of a high water level in the basin. The installer must see that the alarm signal provided is connected to an audible and/or visual alarm in such a manner as to provide adequate warning to the user that service is required. During the interim prior to the arrival of an authorized service technician, water usage must be limited to the reserve capacity of the tank.

**For service, please call your local distributor:**



# Limited Warranty

For E/One Extreme D-Series,  
W-Series & Upgrade

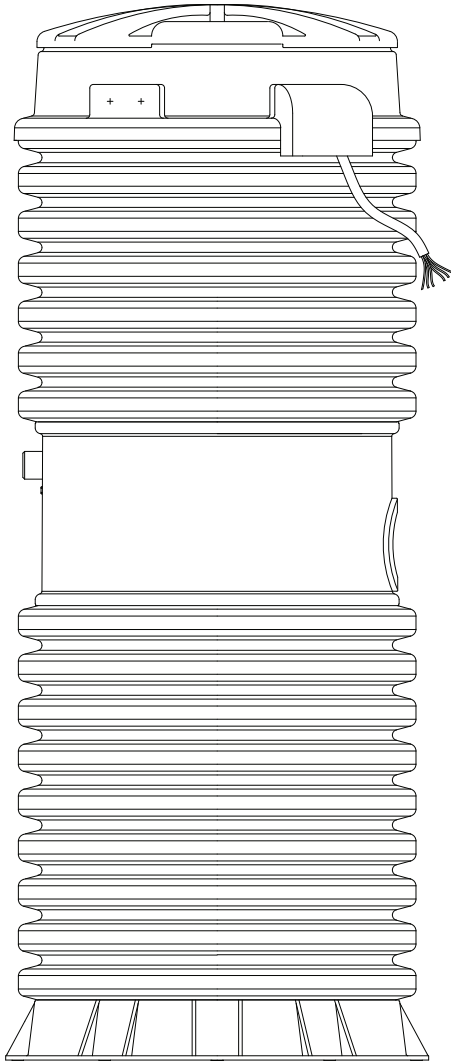

Environment One Corporation offers a limited warranty that guarantees its product to be free from defects in material and factory workmanship for a period of two years from the date of installation, or 27 months from the date of shipment, whichever occurs first, provided the product is properly installed, serviced and operated under normal conditions and according to manufacturer's instructions. Repair or parts replacement required as a result of such defect will be made free of charge during this period upon return of the defective parts or equipment to the manufacturer or its nearest authorized service center.

Model Number: \_\_\_\_\_

Serial Number: \_\_\_\_\_

Installation Date: \_\_\_\_\_



2773 Balltown Rd • Niskayuna NY USA 12309  
(01) 518.346.6161 • [www.eone.com](http://www.eone.com)